

Welcome to
westcoastpoly
COMPLETE TANK SOLUTIONS



JOSH KENNEDY
WEST COAST POLY BRAND AMBASSADOR



PRICE LIST APRIL 2026

WATER TANKS | TROUGHS | CARTAGE | LIQUID FERTILISER | MIXING | FIREGUARD® | DIESEL | RESIDENTIAL



ABOUT US

Opening in 1999, West Coast Poly is proudly West Australian.

From our modern manufacturing facility in Canning Vale, we produce a wide range of products that are part of WA's strong tradition of local manufacturing and innovation.

We are dedicated to producing high-quality, long-lasting polyethylene vessels using a specialised "single piece" moulding method. This seamless process delivers superior strength and durability, perfectly suited to Western Australia's demanding conditions.

Originally focused on agriculture and supporting our state's primary producers, we have expanded to serve the resource, mining, industrial, and civil sectors. Along the way, we have built lasting relationships with a loyal client base that values quality, reliability, and local expertise.

OUR TECHNOLOGY

At West Coast Poly, we're committed to leading the way in roto-moulding technology.

Through continual investment in advanced software, state-of-the-art machinery, and refined manufacturing techniques, we ensure the highest standards of quality.

In 2020, we introduced the SRM 6500 Series 3-Sided Shuttle Machine - one of the largest of its kind - joining our three twin shuttle machines to elevate production. Our 2023 addition, a 4.1m, 4-arm carousel, further boosts capacity and ensures fast, reliable service for our customers.

Every tank we produce is built to meet our **Engineered. Tested. Certified. Trusted.** quality commitment. Each unit undergoes rigorous testing - including ultrasonic wall thickness measurement and low-temperature impact testing - to ensure it is strong, thick-walled, and built to last.

This unwavering focus on quality is why we're ISO and Watermark certified - and why you can always count on a superior, long-lasting tank that's truly built for WA.

BRAND AMBASSADOR - JOSH KENNEDY

Premiership player Josh Kennedy has proudly represented WA on the nation's biggest stage - & now he's teaming up with West Coast Poly to champion local manufacturing and support rural communities.

Having grown up in the regional town of Northampton, Josh understands the challenges of dry conditions and the vital role quality water storage plays across the state.

We also recognise the importance of grassroots footy in bringing people together. Through our 16+ year partnership with the West Australian Country Football League, & now alongside Josh, we're committed to supporting local football & strengthening the communities that support us.





CHAD SOUTHCOTT
WCP GENERAL MANAGER

JOSH KENNEDY
BRAND AMBASSADOR

CONNECT WITH US



Agricultural Range WATER STORAGE TANKS

At West Coast Poly, we make tanks that are built for WA - strong, lightweight, & ready for the toughest conditions.

Our water tanks are easy to install, simple to relocate and built to last. UV-stabilised, rigorously tested, and backed by a 20-year guarantee, they're made for long-term reliability.

Whether it's storing rainwater, stock water, spray water, or bore water, West Coast Poly delivers a water tank that you can rely on.

THE RANGE *See Back Cover for Colour Options*



4,500L



5,300L



9,000L



10,000L



14,000L



23,000L



25,000L



27,500L



38,000L



50,000L





DIMENSIONS & COST

Product Code	Litres	Gallons	Diameter	Inlet Height	Apex Height	Price
WCP4500R	4,500L	1,000 gal.	1.80m	1.95m	2.06m	\$1,575
WCP5300R	5,300L	1,175 gal.	1.92m	2.17m	2.17m	\$1,839
WCP9000R	9,000L	2,000 gal.	2.35m	2.27m	2.38m	\$2,669
WCP10000R	10,000L	2,200 gal.	2.35m	2.60m	2.71m	\$3,389
WCP14000R	14,000L	3,100 gal.	2.87m	2.37m	2.48m	\$3,499
WCP23000R	23,000L	5,100 gal.	3.76m	2.33m	2.45m	\$4,599
WCP25000R	25,000L	5,600 gal.	3.76m	2.50m	2.60m	\$4,989
WCP27500R	27,500L	6,100 gal.	3.76m	2.75m	2.88m	\$5,459
WCP38000R	38,000L	8,400 gal.	4.30m	3.07m	3.19m	\$8,580
WCP50000R	50,000L	11,100 gal.	4.60m	3.30m	3.45m	\$12,129

STANDARD FITTINGS:

- Brass outlet + poly ball valve up to 40mm (1 1/2") (4,500L - 10,000L)
- Brass outlet + poly ball valve up to 50mm (2") (14,000L - 50,000L)
- 90mm overflow
- Leaf strainer and screw top lid
- Available in a range of colours matched to the COLOURBOND® range



Built for Excellence

ENGINEERED. TESTED. CERTIFIED. TRUSTED.

FEA-CERTIFIED DESIGN & UNDERGO ADVANCED ULTRASONIC THICKNESS TESTED

COMBO DEALS

Product Code	Combos	Price
WCP23000RCOM	2 x 23,000L (46,000L)	\$8,965
WCP25000RCOM	2 x 25,000L (50,000L)	\$9,735
WCP27500RCOM	2 x 27,500L (55,000L)	\$10,692
WCP38000RCOM	2 x 38,000L (76,000L)	\$16,775
WCP50000RCOM	2 x 50,000L (100,000L)	\$23,969

Savings up to **\$385** when you buy a Combo



Fast, Simple Set-up,
No On-Site Assembly

INSTALLATION

Scan our QR code for installation of rural tanks guidelines



SEE PAGE 5 FOR RANGE OF ACCESSORIES



WATER STORAGE



ADVANCED MANUFACTURING TECHNOLOGY



MADE IN WESTERN AUSTRALIA



FREE DELIVERY within 800kms of Perth



Agricultural Range WATER TANK EXTRA FITTINGS & ACCESSORIES

PUMPS



DAVEY HS SERIES
Transfer Pump



Davey 5155HV
Fire Pump



DAVEY HP 65-06T
Pressure Pump



DAVEY FIREFIGHTER PUMP
Twin Impeller 5255h



DAVEY YANMAR L70N
Diesel Pump



DAVEY 3" BSP
Gusher Pump



WE HAVE A RANGE OF
DAVEY
SUBMERSIBLE
PUMPS
AVAILABLE

OUTLETS & BALL VALVES

Our outlets & ball valves are WaterMark certified, meaning that each material & product has been rigorously tested and evaluated and certified by a WaterMark Conformity Assessment Body.



(N) Nickel Plated Brass

(P) Polyethylene

Size	Product Code	Brass Outlets	Product Code	Ball Valves
25mm (1")	WCP25BO	\$33	WCP25BV	\$33 (N)
32mm (1 1/4")	WCP32BO	\$44	WCP32BV	\$44 (N)
40mm (1 1/2")	WCP40BO	\$55	WCP40BV	\$55 (P)
50mm (2")	WCP50BO	\$66	WCP50BV	\$77 (P)
80mm (3")*	WCP80BO	\$187	WCP80BV	\$209 (N)

*80mm (3") is Poly welded in.

LEVEL GAUGES

Gauges	Product Code	Price
Express Tank Gauge	WCPETG	\$154
Guided Tank Gauge	WCPGTG	\$275
Hansen Level Alert	WCPHLA	\$364

Tank gauge, supplied only

FLEXIBLE COUPLINGS

Recommended to avoid any loading on the wall/s of storage tanks.



Size	Product Code	Price
40mm (1 1/2")	WCPFLX40X500	\$121
50mm (2")	WCPFLX50X500	\$143
80mm (3")	WCPFLX80X500	\$396

IF YOU REQUIRE A PARTICULAR FITTING NOT SHOWN, PLEASE CONTACT US ON (08) 9456 5888



TANK PLANNER

Round Tanks 4,500L-50,000L



STANDARD LAYOUT

This is how your tank will be set up if you do not specify otherwise.

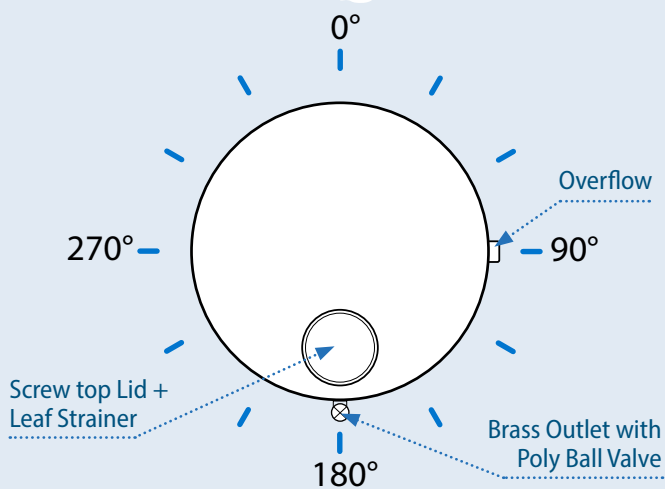

ITEM	POSITION
Screw Top Lid and Leaf Strainer	180°
Brass Outlet with Poly Ball Valve	180°
Overflow	90°

Custom Fit-out

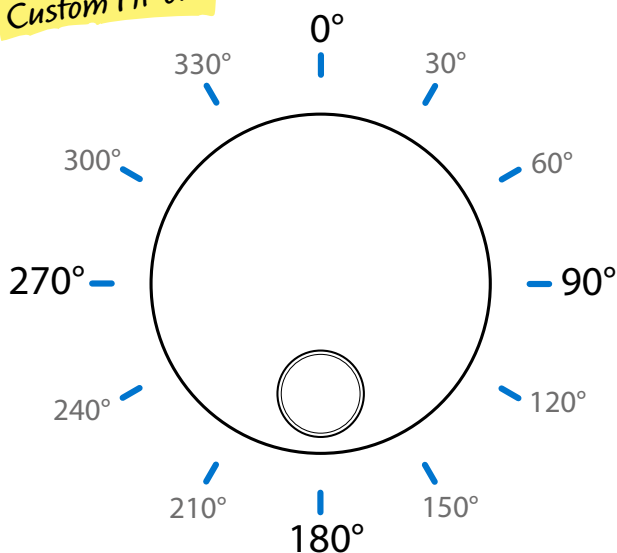

YOUR LAYOUT

Fill in your required positions in the table below.

SIZE (L)	
COLOUR	

ITEM	POSITION
Brass Outlet with Poly Ball Valve	
Addition	
Addition	

OVERFLOW 0° ○ 90° ○ 180° ○ 270° ○

NOTES:





FIRE GUARD

COMPACT FIRE FIGHTING UNITS

“ Compact design fits easily onto ute tray backs, trucks or trailers”

Your first line of fire defence. Our most compact and versatile units, feature a slip-on skid frame for easy deployment and removal from your ute, truck or trailer.

Expertly engineered by our team, this all-in-one unit, comes complete with a fast-release and high output hose reel. Paired with a reliable Davey pump and Honda engine, attached to a galvanised skid frame.

FIREGUARD® COMPACT FIRE FIGHTING UNITS (total dimensions, tank & skid frame)

Product Code	Volume	Width (skid frame)	Length (skid frame)	Height	Price
WCP600FF	600L	1.50m	1.20m	1.115m	\$6,699
WCP800FF	800L	1.50m	1.20m	1.160m	\$6,919
WCP1000FF	1,000L	1.50m	1.20m	1.335m	\$7,139

PRICES INCLUDE: All in one unit, complete with galvanised skid, hose reel, and pump. Full details in standard fittings below.

STANDARD FITTINGS INCLUDE

- 40mm camlock quick connection fittings
- Hinged screw top lid
- Hot dipped galvanised skid with front & side fork tine lifting and tie down points
- Cast aluminium hose reel, fast winding with a reel lock and smooth guide rollers
- 30m x 25mm hose with adjustable flow nozzle
- 6m suction hose with foot valve for fast and efficient self-filling capability
- Davey 5155HV fire pump with a 5.5hp Honda GX160 engine

ADDITIONAL ACCESSORIES



Individual Hose Reel - \$990



Individual Hose Reel with 1" fire hose and nozzle - \$1,276



PUMP UPGRADE AVAILABLE
Davey Firefighter Pump
Twin Impeller 5265HV - \$341

“Low Profile Design For Even Weight Distribution”



FIRE GUARD

SKID MOUNTED FIRE RESPONDERS

Engineered for optimal performance and rapid response, the low-profile design ensures even weight distribution for safe and easy transport.

With user-friendly features and a low-profile design, these units fit neatly on tray-back utes or flatbed trucks. The heavy-duty galvanised steel sled securely bolts the tank, pump, and hose reel for balanced spacing and easy access during critical moments.

FIREGUARD® SKID MOUNTED FIRE RESPONDERS (total dimensions, tank & skid frame)

Product Code	Volume	Width (skid frame) APPROXIMATE	Length (skid frame) APPROXIMATE	Height	Price
WCP600FR	600L	1.50m	1.80m	0.71m	\$6,996
WCP800FR	800L	1.50m	1.80m	0.86m	\$7,238
WCP1000FR	1,000L	1.50m	1.80m	1.06m	\$7,458
WCP1500FR	1,500L	2.00m	2.45m	1.01m	\$8,767
WCP2000FR	2,000L	2.00m	2.45m	1.22m	\$9,559
WCP3000FR	3,000L	2.50m	2.86m	1.27m	\$10,813

PRICES INCLUDE: All in one unit, complete with galvanised skid, hose reel, and pump. Full details in standard fittings below.

STANDARD COLOURS

NATURAL

WHITE

YELLOW

RED

More colours available upon request.

STANDARD FITTINGS INCLUDE

- Davey 5155HV Fire Pump with a 5.5hp Honda GX160 engine
- Cast aluminium hose reel, fast winding with a reel lock & smooth guide rollers
- 30m x 25mm hose with adjustable flow nozzle
- 40mm or 50mm camlock quick connection fittings
- Sight level indicator
- 6m suction hose with a foot valve for fast and efficient self-filling capability
- Hinged screw top lid
- Hot dipped galvanised skid with tie down points

ADDITIONAL ACCESSORIES

- Custom skid frames can be made upon request
- Option to upgrade to a twin impeller or diesel unit



BAFFLE BALLS

LiquidLocker™ supplied by TTI

- Supply only (unassembled) - \$11 (each)
- Assembled & Installed - \$14.30 (each)



FIRE GUARD



ADVANCED
MANUFACTURING
TECHNOLOGY



MADE IN WESTERN
AUSTRALIA



FREE DELIVERY
within 800kms of Perth



For Life on the Land WATER TROUGHS

West Coast Poly's stock troughs offer the highest levels of practicality and reliability

With high volume capability, our troughs are constructed using Linear Medium Density Polyethylene. This makes them tough, durable with high levels of impact resistance, while still being suitable for all water types. Thanks to their clever design, our troughs are easy to maintain and clean, with robust protected fittings so even the most curious livestock can't damage them.

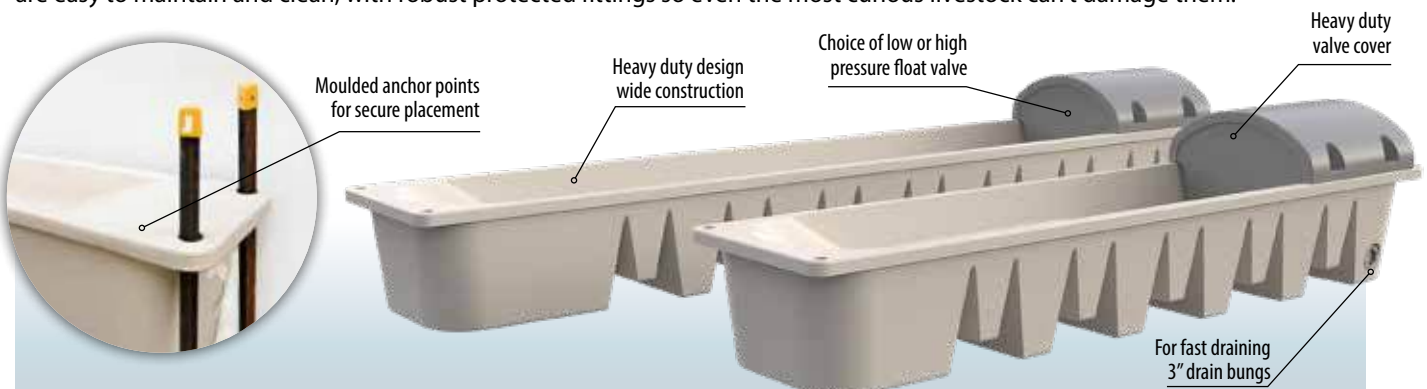

RECTANGULAR SUPA TROUGH

Product Code	Volume	Width	Length	Wall Height	Price
WCP550ST	550L	0.80m	3.40m	0.50m	\$1,793
WCP800ST	800L	0.80m	4.60m	0.50m	\$2,068

INCLUDES: Float valve – standard 1½" (40mm) Poly (2" at additional cost), hold down restraint points both ends, heavy duty float valve cover, fully draining with internal sump and 3" drain bung, easy clean sweep out end.

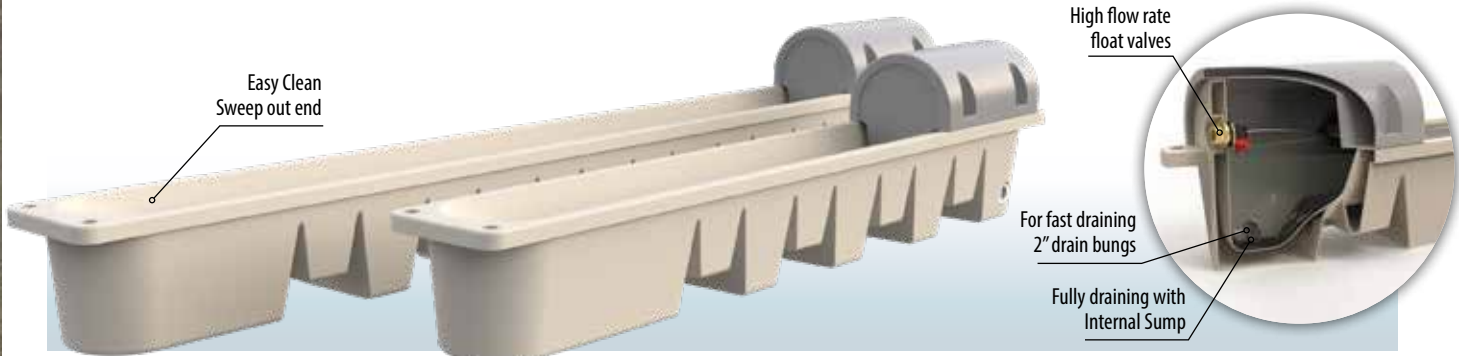

RECTANGULAR LONG TROUGH

Product Code	Volume	Width	Length	Wall Height	Price
WCP170LT	170L	0.42m	3.20m	0.40m	\$1,100
WCP300LT	300L	0.42m	4.60m	0.40m	\$1,320

INCLUDES: High flow float valve – standard 1" (25mm) Poly (1¼", 1½" or 2" at additional cost), hold down restraint points both ends, heavy duty float valve cover, fully draining with internal sump and 2" drain bung, easy clean sweep out end.

“ Experience the best in strength & durability with our round trough

HEAVY DUTY ROUND TROUGH

Product Code	Volume	Diameter	Wall Height	Price
WCP1200RT	1,200L	1.60m	0.60m	\$979

Trough comes complete with tamper resistant float valve & 50mm drain bung. Available in Beige only.





TANK AND DONUT TROUGH

Product Code	WCP4500TD	WCP9000TD
Volume	4,500L	9,000L
Drinking Vol.	330L	420L
Diameter	2.50m	3.05m
Height	2.00m	2.30m
Trough Width	0.325m	0.325m
Price	\$3,498	\$4,708

INCLUDES: 40mm (1½") tank outlet with isolation valve connected to trough float valve with flexible camlock coupling, 40mm trough drain bung & 40mm (1½") brass inlet with 1" (25mm) float valve. (Bottom fill inlet & larger float valves available at additional cost)



For easy connection & separation flexible coupling with camlock connection

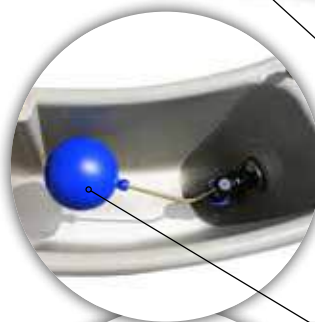

Trough surrounds tank for easier cleaning

High volume, low pressure **FLOAT VALVE** for steady water flow



DONUT TROUGH

Product Code	Volume	Diameter	Height	Trough Width	Price
WCP330DT	330L	2.50m	0.35m	0.325m	\$1,969
WCP420DT	420L	3.05m	0.35m	0.325m	\$2,266

INCLUDES: Removable float valve cover, 40mm drain bung and 40mm (1½") flexible camlock connection



STANDARD COLOUR

BEIGE

5 YEAR
GUARANTEE



WATER STORAGE



ADVANCED
MANUFACTURING
TECHNOLOGY



MADE IN WESTERN
AUSTRALIA



FREE DELIVERY
within 800kms of Perth



Suitable for Water & Liquid Fertiliser

LIQUID CARTAGE TANKS

WATER CARTAGE TANKS

When time efficiency matters, our range of liquid cartage tanks can help make you more productive.

With a range of 600L - 17,000L, like all West Coast Poly products our cartage tanks are designed to be lightweight yet strong & durable for our WA conditions. With large outlets for faster liquid flow, our range of cartage tanks make water transport a breeze.

CARTAGE TANKS - ORIGINAL RANGE

Product Code	Volume	Width	Length	Height	Water
WCP3500WC	3,500L	1.82m	2.37m	1.25m	\$4,224

CARTAGE TANKS

Product Code	Volume	Width	Length	Height	Water
WCP600WC	600L	1.13m	1.23m	0.71m	\$1,199
WCP800WC	800L	1.13m	1.23m	0.86m	\$1,485
WCP1000WC	1,000L	1.13m	1.23m	1.06m	\$1,727
WCP1500WC	1,500L	1.37m	1.73m	1.01m	\$2,387
WCP2000WC	2,000L	1.37m	1.73m	1.22m	\$3,080
WCP3000WC	3,000L	1.63m	2.33m	1.27m	\$4,356
WCP5000WC	5,000L	1.83m	2.58m	1.57m	\$6,105
WCP7000WC	7,000L	2.13m	3.33m	1.53m	\$8,283
WCP8500WC	8,500L	2.13m	3.33m	1.77m	\$9,669
WCP10500WC	10,500L	2.13m	3.83m	1.84m	\$11,275
WCP13000WC	13,000L	2.30m	4.43m	1.82m	\$14,604
WCP15000WC	15,000L	2.30m	4.43m	2.10m	\$17,185
WCP17000WC	17,000L	2.30m	4.43m	2.37m	\$18,968

STANDARD FITTINGS INCLUDE

WATER CARTAGE TANKS - Available in White or Natural (translucent):

600 - 2,000L: Poly outlet up to 50mm (2") with brass ball isolation valve, camlock & cap. Calibrated sight tube, solid stainless steel mounting pins, atmospheric vent and 350mm hinged polypropylene inspection hatch.

3,000 - 7,000L: Poly outlet up to 50mm (2") with brass ball isolation valve, camlock & cap. Inlet with camlock if required. Calibrated Sight tube with isolation valve, solid stainless steel mounting pins, 2 way atmospheric vent and 450mm polypropylene hinged inspection hatch.

8,500 - 17,000L: 1 x Brass outlet up to 80mm (3") with brass ball isolation valve, camlock and cap. Inlet with camlock if required. Calibrated Sight tube with isolation valve, solid stainless steel mounting pins, 2 way atmospheric vent and 450mm polypropylene hinged inspection hatch.



2-Way Atmospheric Vent



Stainless Steel Ball Valve, Camlock & Cap



Calibrated Site Tube



Hinged, Lockable Stainless Steel Lid



Mounting Pins



Stainless Steel Ladder
(Additional option)
\$1,045

LIQUID FERTILISER CARTAGE TANKS

Spend less time filling and more time spraying with our range of fertiliser cartage tanks.

Ranging from 600-17,000 litres, with the largest in the range able to fill up a 5000L sprayer 3.5 times, the equivalent to tripling your sprayer capacity. Constructed using a Linear Medium Density Polyethylene (LMDPE) and quality stainless steel fittings that provide outstanding chemical compatibility, corrosion resistance and faster liquid transfer, saving precious time during your busy periods.

CARTAGE TANKS - ORIGINAL RANGE

Product Code	Volume	Width	Length	Height	Liquid Fertiliser
WCP3500FC	3,500L	1.82m	2.37m	1.25m	\$4,785

CARTAGE TANKS

Product Code	Volume	Width	Length	Height	Liquid Fertiliser
WCP2000FC	2,000L	1.37m	1.73m	1.22m	\$3,575
WCP3000FC	3,000L	1.63m	2.33m	1.27m	\$5,082
WCP5000FC	5,000L	1.83m	2.58m	1.57m	\$7,293
WCP7000FC	7,000L	2.13m	3.33m	1.53m	\$9,900
WCP8500FC	8,500L	2.13m	3.33m	1.77m	\$11,220
WCP10500FC	10,500L	2.13m	3.83m	1.84m	\$13,233
WCP13000FC	13,000L	2.30m	4.43m	1.82m	\$16,621
WCP15000FC	15,000L	2.30m	4.43m	2.10m	\$19,348
WCP17000FC	17,000L	2.30m	4.43m	2.37m	\$22,036

*Sizes 600L - 1,500L available upon request.

STANDARD FITTINGS INCLUDE

LIQUID FERTILISER CARTAGE TANKS - Available in White or Natural (translucent):

2,000L: Poly outlet up to 50mm (2") with stainless steel ball isolation valve, camlock & cap. Calibrated sight tube, solid stainless steel mounting pins, 2 way atmospheric vent and 350mm polypropylene hinged inspection hatch.

3,000 - 7,000L: Poly outlet up to 50mm (2") with stainless steel ball isolation valve, camlock & dust cap. Inlet with camlock if required. Calibrated sight tube with isolation valve, solid stainless steel mounting pins, 2 way atmospheric vent and 400mm stainless steel hinged inspection hatch.

8,500 - 17,000L: Poly outlet up to 80mm (3") with stainless steel ball isolation valve, camlock & dust cap. Inlet with camlock if required. Calibrated sight tube with isolation valve, solid stainless steel mounting pins, 2 way atmospheric vent, 400mm stainless steel hinged inspection hatch.



LIQUID FERTILISER CARTAGE



WATER CARTAGE



ADVANCED MANUFACTURING TECHNOLOGY



MADE IN WESTERN AUSTRALIA



FREE DELIVERY within 800kms of Perth



Prices valid from 13 April 2026. Prices subject to change without notice. All prices include GST.



Suitable For Water & Liquid Fertiliser

LIQUID CARTAGE TANKS

EXTRA FITTINGS & ACCESSORIES

CARTAGE TANKS OPTIONAL EXTRAS:

- Stainless steel ladder for tank sizes 8,500L-17,000L at additional cost - **\$1,045**
- 600mm poly inspection hatch (7,000L-17,000L) - **\$198**
- 600mm stainless steel inspection hatch (7,000L-17,000L) - **\$1,705**
- Skid Frames - **SEE PAGE 14**
- 4" outlets or larger flanged style - **available on request**

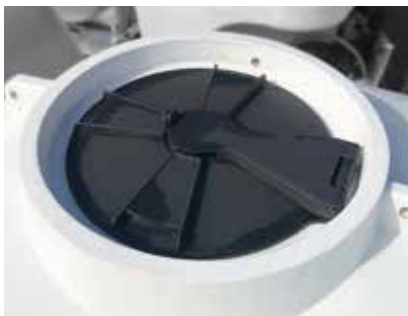

LiquidLocker™ BAFFLE BALLS

Designed for the safer transportation of liquid, the LiquidLocker™ baffle system supplied by TTI reduces liquid surge within the tank when cornering and braking. This improves the safety and stability of your vehicle.

Product Code	Baffle Balls	Unit Price
TTIBAFF	Supply Only - <i>unassembled</i> (1ball per 33L)	\$11
TTIBAFFTP	Assembled & Installed in Tank (1ball per 33L)	\$14.30

*Recommend filling 100% of the tank.

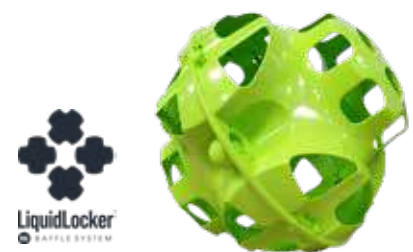

WHY LiquidLocker™ BAFFLE BALLS?

- The irregular shape allows balls to interlock preventing any movement of the balls inside the tank
- Significantly reduces fluid movement for improved load stability during transit
- Food grade quality material, suitable for diesel & other liquids
- Complies with load restraint guide performance standards
- 386g per LiquidLocker™ & it takes up just 1.7% of your tank's total volume



Cartage Tanks SKID FRAMES

SKID FRAMES - CARTAGE TANKS

Our skid frames are designed & made in-house at our modern Canning Vale facility & are commercial heavy duty grade. The West Coast Poly skid frames are HDG (Hot Dipped Galvanised) for high durability. With usability in mind we designed our skid frames with multi sided fork tine lifting points giving you maximum versatility and mobility for your cartage tanks.

We can customise our skid frames to suit whatever needs you require, simply contact our friendly sales team.



RANGE AND DIMENSIONS - Hot dipped Galvanised

Product Code	Volume	Width	Length	Price
WCP600SF	600L	1.13m	1.23m	\$2,607
WCP800SF	800L	1.13m	1.23m	\$2,607
WCP1000SF	1,000L	1.13m	1.23m	\$2,607
WCP1500SF	1,500L	1.37m	1.73m	\$4,378
WCP2000SF	2,000L	1.37m	1.73m	\$4,378
WCP3000SF	3,000L	1.63m	2.33m	\$6,820
WCP5000SF	5,000L	1.83m	2.58m	\$7,282

Product Code	Volume	Width	Length	Price
WCP7000SF	7,000L	2.13m	3.33m	\$9,482
WCP8500SF	8,500L	2.13m	3.33m	\$9,482
WCP10500SF	10,500L	2.13m	3.83m	\$10,032
WCP13000SF	13,000L	2.43m	4.53m	\$10,978
WCP15000SF	15,000L	2.43m	4.53m	\$10,978
WCP17000SF	17,000L	2.43m	4.53m	\$10,978

FOR MORE INFORMATION, CALL OUR SALES TEAM ON (08) 9456 5888

Secure Storage LIQUID FERTILISER

Secure Liquid Fertiliser Storage, so you can focus on the seasons ahead.

Expertly designed these tanks are fully engineered FEA certified, single piece roto-moulded construction for unmatched strength & durability. With a range of clever features and backed by a 15 year guarantee, West Coast Poly has your agricultural liquid fertiliser storage covered, so you can get on with farming.

Product Code	Volume	Volume (Tonne)	Diameter	Apex Height	Price
WCP25000LF	25,000L	33	3.78m	2.60m	\$8,547
WCP50000LF	50,000L	66	4.60m	3.45m	\$16,258



MAX Specific Gravity = 1.32

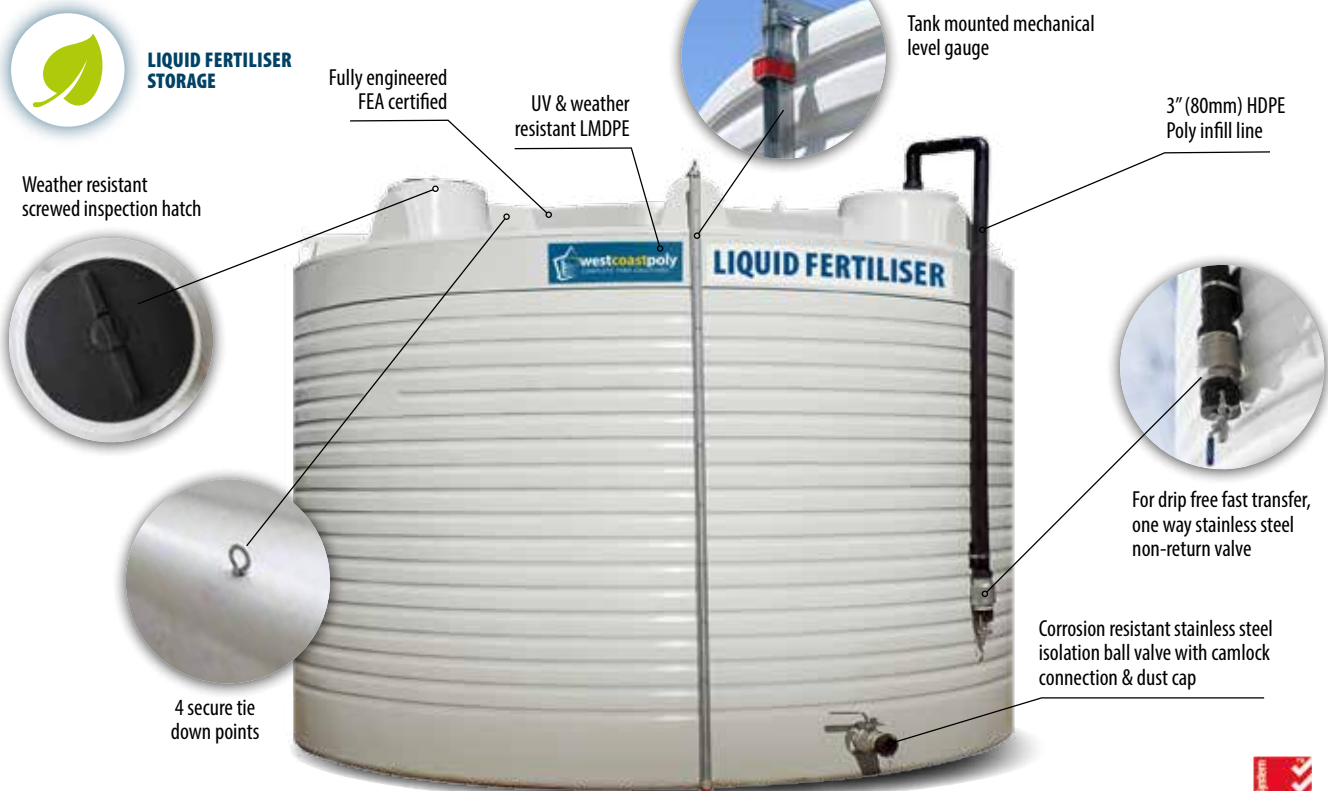

STANDARD FITTINGS INCLUDE

- 3" (80mm) HDPE poly infill line with stainless steel non-return valve, camlock and dust cap and 13mm drain valve
- 2" (50mm) or 3" (80mm) suction outlet – Stainless steel isolation ball valve with camlock connection & dust cap
- Screwed inspection hatch
- Guided Tank Gauge - tank mounted mechanical level gauge
- 4 tie down points
- FEA engineering certified

Fast Batch Turnover FERTILISER MIXING TANKS

Giving you on-site mixing capabilities for agricultural fertiliser mixing, while also providing the flexibility to tailor specific formulas that suit your application needs.

The West Coast Poly mechanical/electric mixer comprises of a vertical prop shaft with a roof mounted electric motor & gearbox, driving a stainless steel prop shaft, designed specifically for your process application.

With our vast tank manufacturing experience, our mechanical mixer engineering team have a mixer tank solution for your needs. Whether it be low level, high velocity or process stirring, fully draining floors, a tank can be made to your requirements.



Product Code	Volume	Height	Diameter	Mixing Volume (Suggested Batch Vol.)	Price
WCP5000MX	5,000L	1.30m	2.35m	4,000L	\$15,756
WCP9000MX	9,000L	1.50m	2.85m	8,000L	\$17,198
WCP14000MX	14,000L	2.20m	2.85m	12,000L	\$17,603
WCP25000MX	25,000L*	2.60m	3.78m	22,000L	\$24,355
WCP38000MX	38,000L*	3.15m	4.30m	35,000L	\$34,497
WCP50000MX	50,000L*	3.45m	4.60m	47,000L	\$39,100

Pricing represents 240v units -415v available on request.

STANDARD FITTINGS INCLUDE

- 240v single batch mixers
- 5,000L to 14,000L: 50mm (2") poly outlet + ball valve
- 25,000L to 50,000L: 80mm (3") poly outlet + stainless steel ball valve.
- Hinged PE loading hatch

ADDITIONAL OPTIONS

- Low level/variable batch mixers
- 415v mixers
- Internal baffles
- Flanged fittings
- Fully draining floor
- Level indicator
- **OTHER TANK SIZES ON REQUEST**

APPLICATIONS

- Chemical applications
- Fertiligation
- Individual recipes combinations
- Broadacre/Viticulture/Horticulture

BENEFITS

- High agitation rate for rapid batch turnaround
- Aggressive floor scouring to prevent sediment
- Versatility to produce specific fertiliser/chemical recipes

*Additional oversize delivery charge P.O.A. 38,000L and 50,000L require mixer to be installed on-site, extra cost involved depending on delivery destination.

Secure Storage DIESEL TANKS

Built tough for secure on-farm diesel storage and efficient diesel handling.

West Coast Poly Diesel Storage Tanks are expertly designed with a suite of clever features. Acting like a suit of armour for your diesel, they protect against contamination and ingress, while enabling faster, more efficient handling. West Coast Poly has your on-farm diesel storage needs covered, so you can focus on farming.

DIESEL STORAGE TANKS + ITALIAN MADE PIUSI PUMP KIT

5,000L	WITH PUMP	NO PUMP
Product Code	WCP5000DSP	WCP5000DS
Diameter	1.93m	1.93m
Apex Height	2.17m	2.17m
Price	\$11,099	\$5,731

10,000L	WITH PUMP	NO PUMP
Product Code	WCP10000DSP	WCP10000DS
Diameter	2.35m	2.35m
Apex Height	2.71m	2.71m
Price	\$12,463	\$7,183



STANDARD FITTINGS INCLUDE

TANKS INCLUDE:

- 50mm (2") fill line
- 40mm lockable drain valve
- Fully sealed roof to prevent water ingress
- Volume level sight tube + isolation valve
- 80mm (3") overflow port with ingress protection & vermin proof screen
- Earth/Ground cable
- Twin vent diesel breather

OTHER SIZES AVAILABLE ON REQUEST

WITH PUMP:

- 12v or 240v Italian made PIUSI Diesel pump kit
- Flow meter sealed within steel cabinet
- Earth/Ground cable
- Flow rates of 80L/min for the 12v and 90L/min for the 240v
- Protective water filter
- Auto shut off nozzle
- Diesel grade delivery hose 12v = 4m hose & 240v = 7.5m hose

STANDARD FOR THE STORAGE OF DIESEL FUEL (AS1940:2017)

West Coast Poly diesel tanks are designed in accordance with AS1940:2017 storage and handling of combustible liquids.

Tank installation including bund requirements are the responsibility of the user and should be as per required in accordance with AS1940:2017.



Secure Storage ADBLUE TANK

West Coast Poly's AdBlue tanks are expertly designed to give you total peace of mind, knowing that your AdBlue is stored securely.

Their heavy duty and single piece roto-moulded construction gives these tanks unmatched strength and durability. While also coming with a Piusi pump kit as standard, to give you easy access to your AdBlue on-site.

For a complete AdBlue storage solution that meets the needs of your modern high performance diesel engines, it has to be West Coast Poly.

ADBLUE STORAGE TANKS + ITALIAN MADE PIUSI PUMP KIT

Product Code	Volume	Diameter	Apex Height	Price
WCP10000AS	10,000L	2.35m	2.71m	\$14,036
WCP5000AS	5,000L	1.93m	2.17m	\$11,539

**OTHER SIZES
AVAILABLE ON
REQUEST**



STANDARD FITTINGS INCLUDE

- 12v or 240v PIUSI AdBlue pump kit with flow meter sealed within steel cabinet
- Flow rate of 35L/min
- 5m delivery hose plus auto shut off nozzle
- 2" fill line
- 40mm lockable drain valve
- Lockable calibrated site tube
- 3" overflow port with ingress protection & vermin proof screen
- Fully sealed roof to prevent water ingress



Secure Storage DIESEL CARTAGE TANK

A hard-wearing workhorse to transport your diesel safely and efficiently.

No matter if you're seeding, spraying or harvesting our Diesel Cartage Tanks will help keep your operation moving forward. Thanks to their meticulous design and our cutting edge Roto-Moulding technology, our Diesel Cartage Tanks are built tough, yet remain lightweight, for efficient diesel transport.



DIESEL CARTAGE TANKS

Product Code	Volume	Width	Length	Height	Price
WCP600DC	600L	1.13m	1.23m	0.71m	\$1,386
WCP800DC	800L	1.13m	1.23m	0.86m	\$1,804
WCP1000DC	1,000L	1.13m	1.23m	1.06m	\$2,024
WCP1500DC	1,500L	1.37m	1.73m	1.01m	\$2,684
WCP2000DC	2,000L	1.37m	1.73m	1.22m	\$3,520
WCP3000DC	3,000L	1.63m	2.33m	1.27m	\$4,994
WCP5000DC	5,000L	1.83m	2.58m	1.57m	\$7,183
WCP7000DC	7,000L	2.13m	3.33m	1.53m	\$9,394
WCP8500DC	8,500L	2.13m	3.33m	1.77m	\$10,868
WCP10500DC	10,500L	2.13m	3.83m	1.84m	\$13,277

STANDARD FITTINGS:

- Anti foaming filling point 50mm (2")
- Twin vent diesel breather
- Lockable ball valve 40mm (1 1/2")
- Lockable calibrated site tube
- Stainless steel mounting pins
- Poly sealed lid

PUMP KITS AND SKID FRAMES AVAILABLE

“Flow rates of up to 120 L/min”



DIESEL CARTAGE PERFORMANCE PUMP PACK

Add our Performance Pump Pack for a fast, efficient diesel transfer solution.

Designed for quick refueling of machinery and site equipment, this plug-and-play setup delivers **flow rates of up to 120 L/min.**

INCLUDES: Standard Diesel Cartage tank plus..

- **Heavy-duty galvanised skid frame** with checker plate pump mount, side fork pockets & lifting points
- **High-flow transfer:** up to 120 L/min
- **Davey 5155HV pump** paired with **Honda GX160 (5.5HP) engine**
- **Water Captor filter (30 micron)**
- **Auto shut-off nozzle** with mounted holder
- **Auto retractable hose reel**
- **25mm x 15m hose** for easy reach around equipment

DIESEL CARTAGE TANKS + PERFORMANCE PUMP PACK

Product Code	Volume	Width	Length	Price
WCP1000PPP	1,000L	1.13m	1.83m	\$12,839
WCP2000PPP	2,000L	1.37m	2.33m	\$15,239

OTHER SIZES AVAILABLE ON REQUEST



DIESEL STORAGE SOLUTIONS



ADVANCED MANUFACTURING TECHNOLOGY



MADE IN WESTERN AUSTRALIA



FREE DELIVERY within 800kms of Perth



Residential Range SLIMLINE & SMALL TANKS

We offer a range of domestic rainwater tanks to suit the suburban environment.



Our tanks are fully certified and manufactured for the household blocks where space is limited. Slimline tanks that fit neatly under the eaves and traditional round tanks make up the residential range.

The rainwater tanks are available in a range of sizes, styles and colours. You are sure to find the perfect tank for your requirements to complement the surrounding environment of your home.

SLIMLINE & SMALL TANK BENEFITS:

- Space saving designs
- Can be placed directly onto pavers
- Reinforced band allows tap placement for easy access
- Easy to relocate
- Manufactured locally in Western Australia with a 10 year guarantee
- Variety of colours, UV resistant

WE MAKE IT EASY TO START COLLECTING RAINWATER



INSTALLATION



Scan me

Scan our QR code for installation of Slimline & Small Tank guidelines

DELIVERY

PLEASE NOTE: A delivery charge of \$143 applies to all Slimline & Small Tanks (320L - 4,500L Mega Slim), delivered direct to customers within 800kms of the Canning Vale factory.

*The 4,500L Mega Slim tank is curbside delivery only.

“Utilise collected rainwater for your washing machine, toilets or water thirsty gardens”

COLOURS AVAILABLE: Indication only. Colours may vary with the printing process. More colours available, see back of brochure.

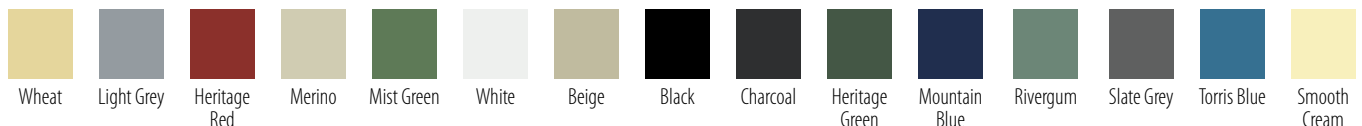



SMALL TANKS

Name/Size	Product Code	Diameter	Wall Height	Height/Inlet	Price
320L Mini	WCP320R	0.59m	1.23m	1.31m	\$629
550L Tall	WCP550R	0.62m	1.99m	2.04m	\$739
720L Courtyard	WCP720R	0.80m	1.50m	1.60m	\$779
1,200L Midi	WCP1200R	1.07m	1.45m	1.60m	\$919
2,500L Suburban	WCP2500R	1.42m	1.62m	1.89m	\$1,229
3,700L Backyard	WCP3700R	1.65m	1.75m	2.07m	\$1,499

SLIMLINE TANKS

Name/Size	Product Code	Height/Inlet	Width	Length	Price
Slimline 1,500L	WCP1500SL	1.87m	0.80m	1.40m	\$1,269
Space Saver 2,500L	WCP2500SL	2.08m	0.72m	2.38m	\$1,929
Terrace 3,000L	WCP3000SL	2.10m	0.80m	2.56m	\$2,099
4,500L Mega Slim	WCP4500SL	2.04m	0.99m	3.10m	\$2,759

YOUR TANK COMES INSTALLED WITH STANDARD FITTINGS:



DRAIN BUNG



MESH LEAF STRAINER



SCREW TOP LID



LEVER ACTION TAP



BUG PROOF OVERFLOW PORT



**WA's
biggest slimline
4,500L
MEGA SLIM**



Slimline tanks: 1,500L, 2,500L, 3,000L



WATER STORAGE



ADVANCED
MANUFACTURING
TECHNOLOGY



MADE IN WESTERN
AUSTRALIA



AUTO RAINWATER HARVESTING SYSTEM

All In One Automatic Rainwater Harvesting Systems.

An all-in-one system where technology does the work for you when it comes to collecting & utilising your rainwater for in-house reuse.

If your rainwater tank is running low, the roof mounted controller automatically switches the water flowing to the house from the tank to water directly from the water mains. Switching back to rainwater automatically once your tank's water is replenished. It will always use rainwater first and you will always have an uninterrupted water flow to your home.

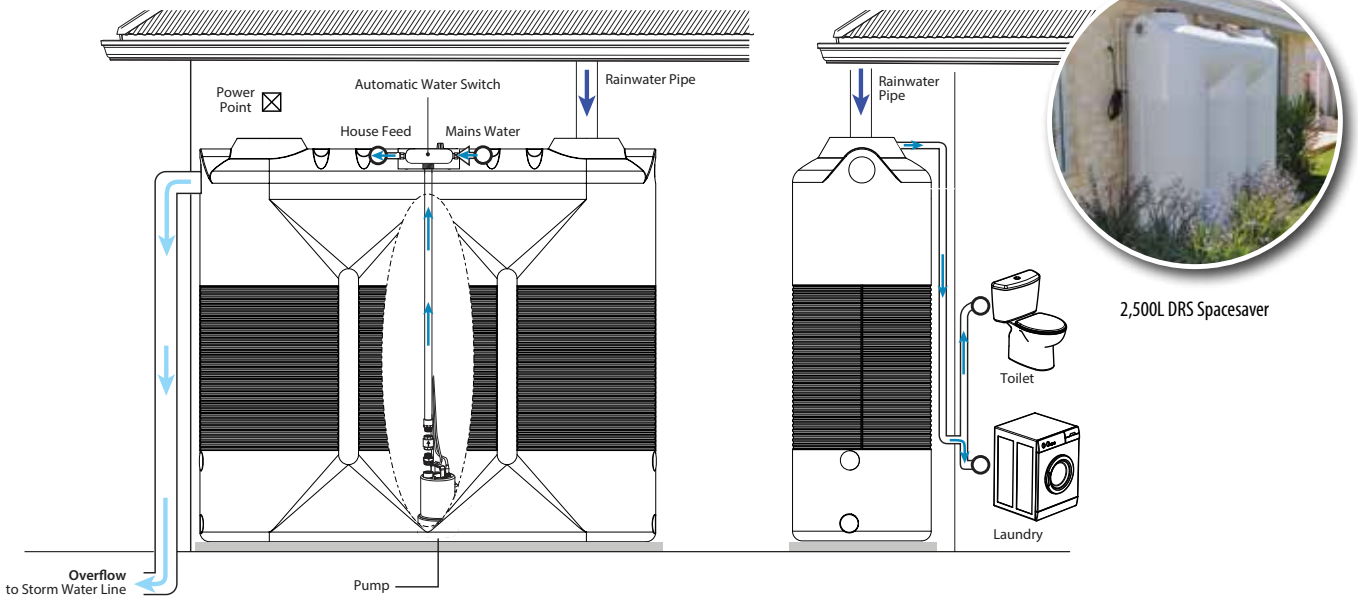

AUTO RAINWATER HARVESTING SYSTEM INCLUDES:



ROOF MOUNTED
AUTO WATER SWITCH
CONTROLLER



DIVERTRON 1200
SUBMERSIBLE PUMP



BUG PROOF
OVERFLOW PORT



MESH
LEAF STRAINER



LEVER
ACTION TAP



SCREW
TOP LID

AUTO RAINWATER HARVESTING SYSTEM + SMALL TANK

Volume	Product Code	Diameter	Wall Height	Height/Inlet	Price
2,500 - DRS Round	WCP2500RDRS	1.42m	1.62m	1.86m	\$3,025

AUTO RAINWATER HARVESTING SYSTEM + SLIMLINE TANK

Volume	Product Code	Height/Inlet	Width	Length	Price
1,500L - DRS Slimline	WCP1500SDRS	1.86m	0.80m	1.40m	\$3,036
2,500L - DRS Spacesaver	WCP2500SDRS	2.08m	0.715m	2.35m	\$3,702
3,000L - DRS Terrace	WCP3000SDRS	1.99m	0.80m	2.52m	\$4,004
4,500L - DRS Mega Slim	WCP4500SDRS	2.00m	0.98m	3.08m	\$4,730

Other tank sizes are available on request. Installation is an additional cost. A delivery charge of \$143 applies to all Slimline & Small Tanks (320L - 4,500L Mega Slim) within 800kms of the Canning Vale factory. *The 4,500L Mega Slimline tank is curbside delivery only.



INSTALL PACKAGE + SYSTEM UPGRADE

Upgrade Your Rainwater Quality - We'll Handle the Installation

Includes: Free Delivery, Installation, First Flush Diverter, Leaf Eater Advanced

Scan our QR code for
Install Package + System
Upgrade pricing.



EXTRA FITTINGS & ACCESSORIES

Build the ideal water tank solution package for your home with our range of quality accessories.

Make sure you make the most of your new water tank and deliver a high volume of quality water into your home.

We have categorised our range of slimline & small tank accessories in 5 easy steps to help you design the perfect water tank solution for your home.

1. COLLECT AND PROTECT YOUR Rainwater

Keep debris out of your rain harvesting system so it stays clean



LEAF EATER ADVANCED - \$77

Easily mounted, it prevents leaves entering the catchment pipes with its fine mesh screen.



TOTAL RAIN - \$165

The ultimate all-in-one rainwater cleaning device, filters leaves and diverts the first flush.

2. DIVERT YOUR RAINWATER

Divert contaminated roof run off keeping your tank clean



FIRST FLUSH WATER DIVERTER - \$66

Gives your tank the best water by diverting the first flush of rainwater from your roof.



FIRST FLUSH CARROT WATER DIVERTER - \$121

Its unique compact design takes up minimal space & diverts the first flush without the chamber.

3. WATER MOVEMENT

Make sure your water flows to where you need it to



ONGA JMP100 PUMP - \$671

An economical household pressure system with high performance & reliability.



DAVEY HP65-06T WITH TORRIUM2 - \$1,518

Offers perfect water pressure with a small water pump that can fit into a tight spot.

4. FINAL STAGE FILTRATION

Ensure your water is ready to use through proper filtering



DAVEY TWIN FILTER HOUSINGS KAS10J - \$528

Davey twin filter housing kits are assembled side by side on a stylish bracket for ease of installation.



DAVEY UV WATER DISINFECTION KUV57A - \$2,354

Delivers safe, clean water - using the power of ultraviolet light for reliable, effective, chemical-free disinfection.

OTHER FILTRATION SOLUTIONS AVAILABLE UPON REQUEST

5. MONITOR YOUR WATER LEVEL

Solutions that allows you to check the water level in your tank at a glance

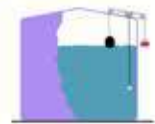

EXPRESS TANK GAUGE - \$154

Accurately shows the level of water on the water tank wall. Great for tanks on stands & residential tanks.

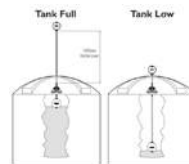

HANSEN LEVEL ALERT - \$364

A maintenance free simple fluid level indicator that can be mounted on tank. Features easy adjust nut & security lock, HiViz Low wind resistant float & stainless steel fastenings.

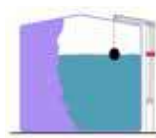

GUIDED TANK GAUGE - \$275

The Liquidator uses a vertical guide tube. The indicator slides up and down on the outside of the tube while the counterweight is contained in it.

PRODUCT PRICE LIST

Effective April 13th 2026

AGRICULTURAL RANGE

WATER STORAGE TANKS

Product Code	Volume	Price
WCP4500R	4,500L	\$1,575
WCP5300R	5,300L	\$1,839
WCP9000R	9,000L	\$2,669
WCP10000R	10,000L	\$3,389
WCP14000R	14,000L	\$3,499
WCP23000R	23,000L	\$4,599
WCP25000R	25,000L	\$4,989
WCP27500R	27,500L	\$5,459
WCP38000R	38,000L	\$8,580
WCP50000R	50,000L	\$12,129

WATER STORAGE TANKS COMBO RANGE

Product Code	Combos	Price
WCP23000RCOM	2 x 23,000L (46,000L)	\$8,965
WCP25000RCOM	2 x 25,000L (50,000L)	\$9,735
WCP27500RCOM	2 x 27,500L (55,000L)	\$10,692
WCP38000RCOM	2 x 38,000L (76,000L)	\$16,775
WCP50000RCOM	2 x 50,000L (100,000L)	\$23,969

FLEXIBLE COUPLINGS

Product Code	Size	Price
WCPFLX40X500	40mm (1 1/2")	\$121
WCPFLX50X500	50mm (2")	\$143
WCPFLX80X500	80mm (3")	\$396

BALL VALVES

Product Code	Size	Price
WCP25BV	25mm (1")	\$33
WCP32BV	32mm (1 1/4")	\$44
WCP40BV	40mm (1 1/2")	\$55
WCP50BV	50mm (2")	\$77
WCP80BV	80mm (3")	\$209

BRASS OUTLETS

Product Code	Size	Price
WCP25BO	25mm (1")	\$33
WCP32BO	32mm (1 1/4")	\$44
WCP40BO	40mm (1 1/2")	\$55
WCP50BO	50mm (2")	\$66
WCP80BO	80mm (3")	\$187

LEVEL GAUGES

Product Code	Gauges	Price
WCPETG	Express Tank Gauge	\$154
WCPGTG	Guided Tank Gauge	\$275
WCPHLA	Hansen Level Alert	\$364

Tank gauge, supplied only

FIRE GUARD - COMPACT FF UNITS

Product Code	Volume	Price
WCP600FF	600L	\$6,699
WCP800FF	800L	\$6,919
WCP1000FF	1,000L	\$7,139

FIRE GUARD SKID MOUNTED FIRE RESPONDERS

Product Code	Volume	Price
WCP600FR	600L	\$6,996
WCP800FR	800L	\$7,238
WCP1000FR	1,000L	\$7,458
WCP1500FR	1,500L	\$8,767
WCP2000FR	2,000L	\$9,559
WCP3000FR	3,000L	\$10,813

FIREGUARD OPTIONAL EXTRAS

Product Code	Gauges	Price
WCPR	Individual Hose Reel	\$990
WCPHR	Individual Hose Reel + 1" Fire Hose & Nozzle	\$1,276

RECTANGULAR SUPA TROUGH

Product Code	Volume	Price
WCP550ST	550L	\$1,793
WCP800ST	800L	\$2,068

RECTANGULAR LONG TROUGH

Product Code	Volume	Price
WCP170LT	170L	\$1,100
WCP300LT	300L	\$1,320

HEAVY DUTY ROUND TROUGH

Product Code	Volume	Price
WCP1200RT	1,200L	\$979

TANK AND DONUT TROUGH

Product Code	Vol	Drinking Vol	Price
WCP4500TD	4,500L	330L	\$3,498
WCP9000TD	9,000L	420L	\$4,708

DONUT TROUGH

Product Code	Volume	Price
WCP330DT	330L	\$1,969
WCP420DT	420L	\$2,266

CARTAGE TANKS

Product Code	Volume	Water
WCP600WC	600L	\$1,199
WCP800WC	800L	\$1,485
WCP1000WC	1,000L	\$1,727
WCP1500WC	1,500L	\$2,387
WCP2000WC	2,000L	\$3,080
WCP3000WC	3,000L	\$4,356
WCP5000WC	5,000L	\$6,105
WCP7000WC	7,000L	\$8,283
WCP8500WC	8,500L	\$9,669
WCP10500WC	10,500L	\$11,275
WCP13000WC	13,000L	\$14,604
WCP15000WC	15,000L	\$17,185
WCP17000WC	17,000L	\$18,968

CARTAGE TANKS - ORIGINAL RANGE

Product Code	Volume	Water
WCP3500WC	3,500L	\$4,224

CARTAGE TANKS - ORIGINAL RANGE

Product Code	Volume	Liquid Fert
WCP3500FC	3,500L	\$4,785

CARTAGE TANKS

Product Code	Volume	Liquid Fert
WCP2000FC	2,000L	\$3,575
WCP3000FC	3,000L	\$5,082
WCP5000FC	5,000L	\$7,293
WCP7000FC	7,000L	\$9,900
WCP8500FC	8,500L	\$11,220
WCP10500FC	10,500L	\$13,233
WCP13000FC	13,000L	\$16,621
WCP15000FC	15,000L	\$19,348
WCP17000FC	17,000L	\$22,036

CARTAGE TANKS OPTIONAL EXTRAS

Product Code	Gauges	Price
WCPSSL	SS ladder (8,500L-17,000L)	\$1,045
WCP600PIH	600mm Poly Inspection hatch (7,000L-17,000L)	\$198
WCP600SIH	600mm SS Inspection hatch (7,000L-17,000L)	\$1,705

LIQUID LOCKER™ Baffle Balls

Product Code	Baffle Balls	Unit Price
TTIBAFF	Supply Only - unassembled (1ball per 33L)	\$11
TTIBAFFTP	Assembled & Installed (1ball per 33L)	\$14.30

LIQUID FERTILISER MIXING TANKS

Product Code	Volume	Price
WCP5000MX	5,000L	\$15,756
WCP9000MX	9,000L	\$17,198
WCP14000MX	14,000L	\$17,603
WCP25000MX	25,000L*	\$24,355
WCP38000MX	38,000L*	\$34,497
WCP50000MX	50,000L*	\$39,100

*Additional oversize delivery charge P.O.A.

LIQUID FERTILISER STORAGE TANKS

Product Code	Volume	Price
WCP25000LF	25,000L (33T)	\$8,547
WCP50000LF	50,000L (66T)	\$16,258

DIESEL STORAGE TANKS + ITALIAN MADE PIUSI PUMP KIT

Product Code	Volume	WITH PUMP
WCP5000DSP	5,000L	\$11,099
WCP10000DSP	10,000L	\$12,463

DIESEL STORAGE TANKS

Product Code	Volume	NO PUMP
WCP5000DS	5,000L	\$5,731
WCP10000DS	10,000L	\$7,183

ADBLUE STORAGE TANK + ITALIAN MADE PIUSI PUMP KIT

Product Code	Volume	WITH PUMP
WCP10000AS	10,000L	\$14,036
WCP5000AS	5,000L	\$11,539

DIESEL CARTAGE TANKS

Product Code	Volume	Price
WCP600DC	600L	\$1,386
WCP800DC	800L	\$1,804
WCP1000DC	1,000L	\$2,024
WCP1500DC	1,500L	\$2,684
WCP2000DC	2,000L	\$3,520
WCP3000DC	3,000L	\$4,994
WCP5000DC	5,000L	\$7,183
WCP7000DC	7,000L	\$9,394
WCP8500DC	8,500L	\$10,868
WCP10500DC	10,500L	\$13,277

DIESEL CARTAGE TANKS + PERFORMANCE PUMP PACK

Product Code	Volume	Price
WCP1000PPP	1,000L	\$12,839
WCP2000PPP	2,000L	\$15,239

SKID FRAMES - Hot Dipped Galvanised

Product Code	Volume	Price
WCP600SF	600L	\$2,607
WCP800SF	800L	\$2,607
WCP1000SF	1,000L	\$2,607
WCP1500SF	1,500L	\$4,378
WCP2000SF	2,000L	\$4,378
WCP3000SF	3,000L	\$6,820
WCP5000SF	5,000L	\$7,282
WCP7000SF	7,000L	\$9,482
WCP8500SF	8,500L	\$9,482
WCP10500SF	10,500L	\$10,032
WCP13000SF	13,000L	\$10,978
WCP15000SF	15,000L	\$10,978
WCP17000SF	17,000L	\$10,978

RESIDENTIAL RANGE

SMALL TANKS

Product Code	Name/Size	Price
WCP320R	320L Mini	\$629
WCP550R	550L Tall	\$739
WCP720R	720L Courtyard	\$779
WCP1200R	1,200L Midi	\$919
WCP2500R	2,500L Suburban	\$1,229
WCP3700R	3,700L Backyard	\$1,499

SLIMLINE TANKS

Product Code	Name/Size	Price
WCP1500SL	Slimline 1,500L	\$1,269
WCP2500SL	Space Saver 2,500L	\$1,929
WCP3000SL	Terrace 3,000L	\$2,099
WCP4500SL	Mega Slim 4,500L	\$2,759

AUTO RAINWATER HARVESTING SYSTEM AND TANK

Product Code	Name/Size	Price
WCP2500RDRS	2,500 - DRS Round	\$3,025
WCP1500SDRS	1,500L - DRS Slimline	\$3,036
WCP2500SDRS	2,500L - DRS Spacesaver	\$3,702
WCP3000SDRS	3,000L - DRS Terrace	\$4,004
WCP4500SDRS	Mega Slim 4,500L	\$4,730

TANK ACCESSORIES (RESIDENTIAL)

Product Code	Product	Price
WCPLEA	Leaf Eater Advanced	\$77
WCPTR	Total Rain	\$165
WCPFFWD	First Flush Water Diverter	\$66
WCPFFCWD	First Flush Carrot Water Diverter	\$121
WCPJMMMP	Onga JMP 100 Pump	\$671
WCPDTP	Davey HP65-06T + Torrium2	\$1,518
WCPDTFHP	Davey Twin Filter Housing KAS10J	\$528
WCPDUVWD	Davey UV Water Disinfection KUV57A	\$2,354
WCPETG	Express Tank Gauge	\$154
WCPGTG	Guided Tank Gauge	\$275
WCPHLA	Hansen Level Alert	\$364



Colour Range

Colours in brackets (colour matching guide): COLOURBOND® colours

NOTE: Colours shown are an indication only, colours may vary. If colour required not shown, contact us for more options.



Built in Western Australia.

Copyright of material displayed in this brochure remains the property of West Coast Poly Pty Ltd.



Delivery:

WATER TANKS (Agricultural Range 4,500L-50,000L)
- Free Delivery (within 800kms from Perth)

Our water tanks are fitted out in our factory & delivery is efficient with a fast turnaround from order to delivery. All tanks come in our standard fitting orientation, unless otherwise specified at time of order.

SMALL WATER TANKS (320L- 4,500L SLIMLINE*)
- Delivery Fee \$143

In the Perth metro area urban tanks are delivered directly to residences by West Coast Poly's fleet of trucks.

*The 4,500L Mega Slimline tank is curbside delivery only.

Available from: