

Welcome to

westcoastpoly

COMPLETE TANK SOLUTIONS



JOSH KENNEDY
WEST COAST POLY BRAND AMBASSADOR



PRICE LIST 2024

AGRICULTURAL | TROUGHES | CARTAGE | LIQUID FERTILISER | MIXING | FIREGUARD® | DIESEL | RESIDENTIAL



ABOUT US

Family owned... and family operated, West Coast Poly is proudly West Australian.

Manufacturing our range of products from our modern facility in Canning Vale, we are proud to be part of our great state's rich heritage of local manufacturing & innovation.

We first opened our doors in 1999, with an ambition to produce the highest quality & robust, long lasting polyethylene storage tanks, that are perfectly suited for our states farmers. Vessels that were West Australian designed and moulded in a "one piece" method offering an unmatched strength and durability suited to our unique West Australian environment.

As West Coast Poly continued to grow and develop throughout our journey, our customers have grown with us, establishing a loyal long term clientele. Originating in agriculture servicing our states primary producers, then expanding throughout the states resource, mining, industrial and civil sectors.

OUR TECHNOLOGY

We always strive to be at the forefront of the latest roto-moulding technology, we are continuously investing in the latest software, machine technology and refining our techniques.

In 2020 we introduced the new SRM 6500 Series 3-Sided Shuttle Rotomoulding Machine, one of the largest machines of its type. Along with our 3 large twin shuttle machines, our manufacturing process is second to none.

In 2023 we also added our 5th machine, 4.1m 4 arm carousel, with capabilities of running 4 cycles at once. This new machine will help us continue to grow & help us maintain our high level of customer service.

Every tank that we manufacture is rigorously tested, through methods of ultrasonic measurement and low temperature impact testing. Ensuring the walls are thick, strong and rigid. This testing is one of the reasons we are ISO & Watermark certified and why you always get a superior quality long lasting WA made tank.

BRAND AMBASSADOR - JOSH KENNEDY

Premiership player Josh Kennedy has represented our state upon the nations biggest stage. Now he is teaming up with us to represent local manufacturing & local rural communities.

Growing up in the regional town of Northampton, WA, Josh has seen plenty of dry days & knows the importance of quality water storage. We also know the importance of grass roots footy in the country, & how it brings our communities together.

Along with our 16 year partnership with the WACFL, Josh & West Coast Poly are trying to enrich our local footy & our local communities.





CHAD SOUTHCOTT
WCP SALES MANAGER

JOSH KENNEDY
AFL SUPER STAR

CONNECT WITH US



Water Storage Tanks

AGRICULTURAL RANGE

Our agricultural water storage tanks have the great advantage of being strong, durable and lightweight, making them versatile and even relocatable if required.

A great choice for storing stock, spray, household water, as well as bore water with elevated salt or iron content. Standard fittings are installed into your tank at the time of delivery, to best suit your needs.

THE RANGE



4,500L



5,300L



9,000L



10,000L



14,000L



23,000L



25,000L



27,500L



38,000L



50,000L



COLOURS AVAILABLE: Indication only. Colours may vary with the printing process. More colours available, see back of brochure.

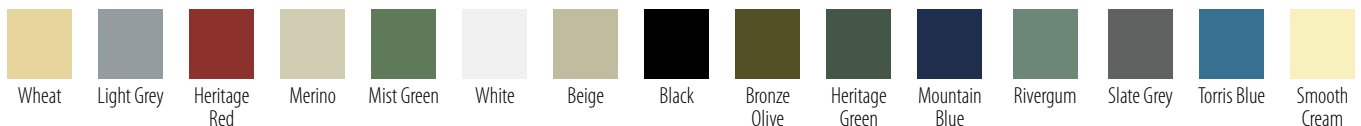



DIMENSIONS & COST

Product Code	Litres	Gallons	Diameter	Inlet Height	Apex Height	Price
WCP4500R	4,500L	1,000 gal.	1.80m	1.89m	2.00m	\$1,309
WCP5300R	5,300L	1,175 gal.	1.93m	2.07m	2.07m	\$1,518
WCP9000R	9,000L	2,000 gal.	2.35m	2.19m	2.30m	\$2,134
WCP10000R	10,000L	2,200 gal.	2.35m	2.53m	2.64m	\$2,541
WCP14000R	14,000L	3,100 gal.	2.85m	2.34m	2.45m	\$2,739
WCP23000R	23,000L	5,100 gal.	3.78m	2.27m	2.40m	\$3,707
WCP25000R	25,000L	5,600 gal.	3.78m	2.47m	2.60m	\$3,872
WCP27500R	27,500L	6,100 gal.	3.78m	2.69m	2.82m	\$4,411
WCP38000R	38,000L	8,400 gal.	4.30m	3.07m	3.15m	\$6,996
WCP50000R	50,000L	11,100 gal.	4.60m	3.30m	3.45m	\$9,372

“

Fitted out for you at time of delivery”

STANDARD FITTINGS:

- Brass outlet + poly ball valve up to 40mm (1 1/2") (4,500L - 10,000L)
- Brass outlet + poly ball valve up to 50mm (2") (14,000L - 50,000L)
- 90mm overflow
- Leaf strainer and screw top lid
- Available in a range of colours matched to the Colorbond® range

A combo deal is a great way to maximise your water usage versatility

Through linking your tanks, you can increase your water usage options or alternatively by having two tanks in separate locations, you can increase your rainwater harvesting efficiency.

COMBO DEALS

Product Code	Combos	Price
WCP23000RCOM	2 x 23,000L (46,000L)	\$7,238
WCP25000RCOM	2 x 25,000L (50,000L)	\$7,590
WCP27500RCOM	2 x 27,500L (55,000L)	\$8,536
WCP38000RCOM	2 x 38,000L (76,000L)	\$13,607
WCP50000RCOM	2 x 50,000L (100,000L)	\$18,348



CUSTOM TANKS

configured to your specific requirements are available, speak to our Technical Division on **(08) 9456 5888**

INSTALLATION

Scan our QR code for installation of rural tanks guidelines



SEE PAGE 5 FOR RANGE OF ACCESSORIES



WATER STORAGE



ADVANCED MANUFACTURING TECHNOLOGY



MADE IN WESTERN AUSTRALIA



FREE DELIVERY within 800kms of Perth



Water Storage Tanks AGRICULTURAL RANGE

EXTRA FITTINGS & ACCESSORIES

TRANSFER / PRESSURE / FIRE FIGHTING PUMPS



DAVEY HS SERIES
Transfer Pump



Davey 5155HV
Fire Pump



DAVEY HP 65-06T
Pressure Pump



DAVEY FIREFIGHTER PUMP
Twin Impeller 5255h



DAVEY YANMAR L70N
Diesel Pump



DAVEY 3" BSP
Gusher Pump



WE HAVE A RANGE OF
**DAVEY
SUBMERSIBLE
PUMPS**
AVAILABLE

OUTLETS & BALL VALVES

Our outlets & ball valves are Watermarked certified, meaning that each material & product has been rigorously tested and evaluated and certified by a WaterMark Conformity Assessment Body.



(N) Nickel plated Brass

(P) Polyethylene

Size	Product Code	Brass Outlets	Product Code	Ball Valves
25mm (1")	WCP25BO	\$22	WCP25BV	\$22 (N)
32mm (1 1/4")	WCP32BO	\$33	WCP32BV	\$33 (N)
40mm (1 1/2")	WCP40BO	\$44	WCP40BV	\$44 (P)
50mm (2")	WCP50BO	\$55	WCP50BV	\$66 (P)
80mm (3")*	WCP80BO	\$176	WCP80BV	\$198 (N)

*80mm (3") is Poly welded in.

LEVEL GAUGES

Gauges	Product Code	Price
Levetator – Level Indicator	WCPLI	\$132
Liquidator v2	WCPLV2	\$275
Hansen Level Alert	WCPHLA	\$286

Level gauge, supplied only

FLEXIBLE COUPLINGS

Recommended to avoid any loading on the wall/s of storage tanks.



500mm plus fittings

Size	Product Code	Price
40mm (1 1/2")	WCPFLX40X500	\$110
50mm (2")	WCPFLX50X500	\$132
80mm (3")	WCPFLX80X500	\$242

IF YOU REQUIRE A PARTICULAR FITTING NOT SHOWN, PLEASE CONTACT US ON (08) 9456 5888



Agricultural Range

FREE DELIVERY

within 800kms of Perth

Our logistics and transport team make sure your tank is delivered safely and on time.

Using our large fleet of trucks, that are equipped with purpose-built trays and low-profile trailers for safe and efficient transport to site. Our fleet of trucks are dispatched throughout the state each week, ensuring a prompt delivery of your tank. And because of our large fleet size, we can offer you the flexibility of a quick order turn-around if required.

As part of our delivery service, our transport team members will install the tanks standard fittings for you on site. From our factory to your door, in the hands of West Coast Poly's professional logistics team & delivery drivers, you can be sure of an smooth delivery and fit-out of your tanks.

If you have any variations or special requirements when it comes to your delivery, discuss it with our team at the time of quotation or order.

“

Just a quick note, our delivery this week was great. Dale was very professional, safe and friendly + communicated delivery clearly and in a timely manner. He made set up look like a breeze... again thanks Dale.

Sue & Arnold W





FIREGUARD®

COMPACT FIRE FIGHTING UNITS

“ Compact design to fits easily onto ute tray backs, trucks or trailers”

Designed with size in mind, these compact units easily fit on your tray back ute or trailer and are quickly readied for action.

Expertly engineered by our team this all-in-one unit, comes complete with a fast release and high output hose reel. Paired with a reliable davey pump and honda engine, attached to a galvanised skid frame.

FIREGUARD® COMPACT FIRE FIGHTING UNITS (total dimensions, tank & skid frame)

Product Code	Volume	Width (skid frame)	Length (skid frame)	Height	Price
WCP600FF	600L	1.50m	1.20m	1.115m	\$5,797
WCP800FF	800L	1.50m	1.20m	1.160m	\$5,995
WCP1000FF	1,000L	1.50m	1.20m	1.335m	\$6,182

PRICES INCLUDE: All in one unit, complete with galvanised skid, hose reel, and pump. Full details in standard fittings below.

STANDARD FITTINGS INCLUDE

- 40mm Camlock quick connection fittings
- Hinged screw top lid
- Hot dipped galvanised skid with front & side fork tine lifting and tie down points
- Cast Aluminium Hose reel, fast winding with a reel lock and easy guide rails
- 30m x 25mm hose with adjustable flow nozzle
- 6m suction hose with foot valve for fast and efficient self-filling capability
- Davey 5155HV Fire Pump with a 5.5hp HondaGX160 engine
- Level site tube indicator

ADDITIONAL ACCESSORIES



Individual Hose Reel - \$990



Individual Hose Reel with 1" fire hose and nozzle - \$1,276



PUMP UPGRADE AVAILABLE
Davey Firefighter Pump
Twin Impeller 5265HV - \$319

“Your first line of defence against a fire outbreak”



FIREGUARD®

SKID MOUNTED FIRE RESPONDERS

Give yourself rapid response capabilities in a fire emergency with our Skid Mounted Fire Responder.

Boasting user friendly features and a low-profile design, making them capable of fitting on your ute tray or truck easily. So you can count on Fire Guard as your reliable and portable firefighting defence unit solution during emergencies.

FIREGUARD® SKID MOUNTED FIRE RESPONDERS (total dimensions, tank & skid frame)

Product Code	Volume	Width (skid frame) APPROXIMATE	Length (skid frame) APPROXIMATE	Height	Price
WCP600FR	600L	1.50m	1.8m	0.71m	\$5,797
WCP800FR	800L	1.50m	1.8m	0.86m	\$5,995
WCP1000FR	1,000L	1.50m	1.8m	1.06m	\$6,182
WCP1500FR	1,500L	2.0m	2.0m	1.01m	\$7,590
WCP2000FR	2,000L	2.0m	2.0m	1.22m	\$7,920
WCP3000FR	3,000L	2.0m	2.0m	1.27m	\$8,965

PRICES INCLUDE: All in one unit, complete with galvanised skid, hose reel, and pump. Full details in standard fittings below.

STANDARD COLOURS

NATURAL

WHITE

YELLOW

RED

More colours available on upon request.

STANDARD FITTINGS INCLUDE

- Davey 5155HV Fire Pump with a 5.5hp Honda GX160 Engine
- Cast Aluminium Hose Reel, fast winding with a reel lock & easy guide rails
- 30m x 25mm hose with adjustable flow nozzle
- 40mm or 50mm camlock quick connection fittings
- Sight Level indicator
- 6m Suction hose with a foot valve for fast and efficient self-filling capability
- Hinged screw top lid
- Hot dipped galvanised skid with tie down points

ADDITIONAL ACCESSORIES

- Custom skid frames can be made upon request
- Option to upgrade to a twin impeller or diesel unit



BAFFLE BALLS

Supply only
(unassembled) - **\$8.80** (each)

Assembled & Installed - **\$12.10** (each)



FIRE GUARD



ADVANCED
MANUFACTURING
TECHNOLOGY



MADE IN WESTERN
AUSTRALIA



FREE DELIVERY
within 800kms of Perth



For Life on the Land WATER TROUGHS

West Coast Poly's stock troughs offer the highest levels of practicality and reliability

With high volume capability, our troughs are constructed using Linear Medium Density Polyethylene. Making them tough, durable with high levels of impact resistance, while still being suitable for all water types. Thanks to their clever design, our troughs are easy to maintain and clean, with robust protected fittings so even the most curious livestock can't damage them.

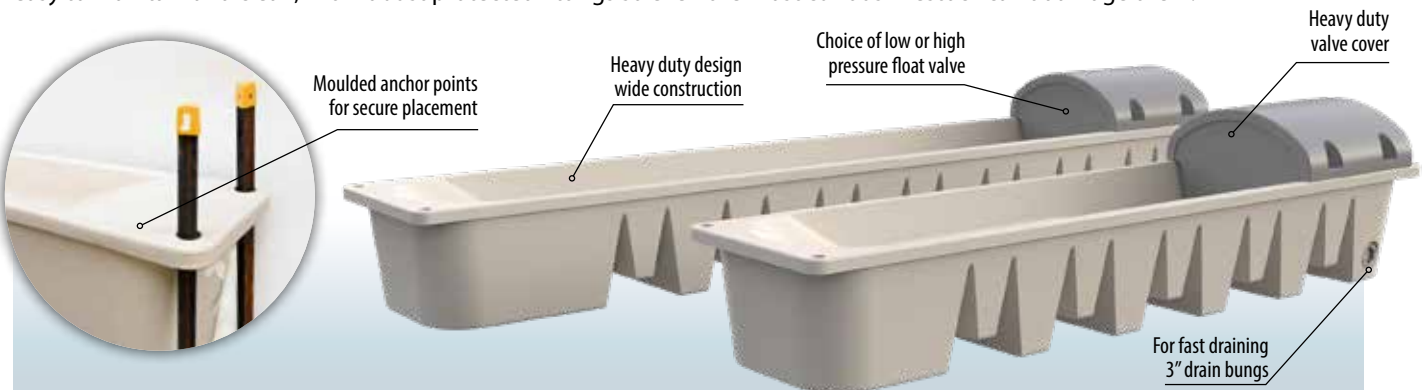

RECTANGULAR SUPA TROUGH

Product Code	Volume	Width	Length	Wall Height	Price
WCP1550ST	550L	0.80m	3.40m	0.50m	\$1,485
WCP800ST	800L	0.80m	4.60m	0.50m	\$1,705

INCLUDES: Float valve – standard 1½" (40mm) Poly (2" at additional cost), hold down restraint points both ends, heavy duty float valve cover, fully draining with internal sump and 3" drain bung, easy clean sweep out end.

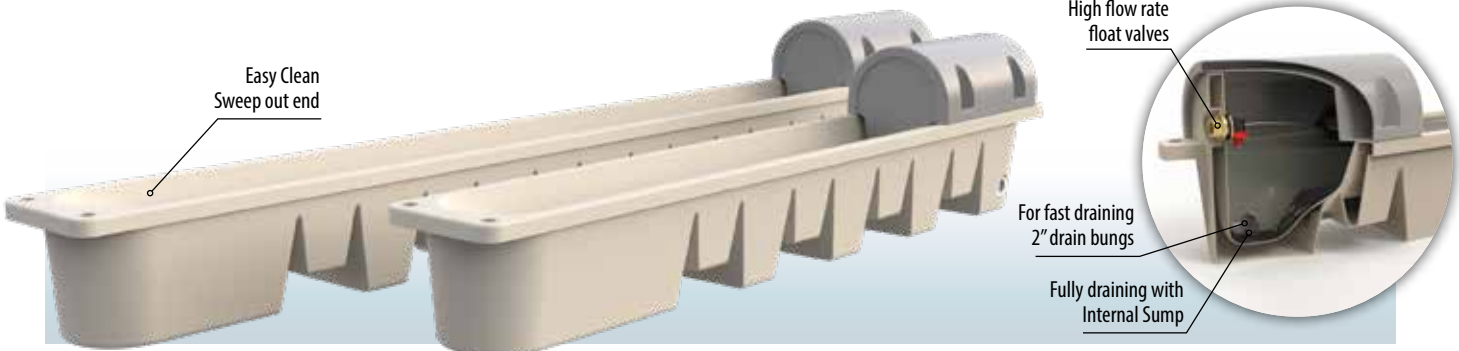

RECTANGULAR LONG TROUGH

Product Code	Volume	Width	Length	Wall Height	Price
WCP170LT	170L	0.42m	3.20m	0.40m	\$913
WCP300LT	300L	0.42m	4.60m	0.40m	\$1078

INCLUDES: High flow float valve – standard 1" (25mm) Poly (1¼", 1½" or 2" at additional cost), hold down restraint points both ends, heavy duty float valve cover, fully draining with internal sump and 2" drain bung, easy clean sweep out end.

“Bringing the best in strength and durability in a round trough”

HEAVY DUTY ROUND TROUGH

Product Code	Volume	Diameter	Wall Height	Price
WCP1200RT	1,200L	1.60m	0.60m	\$814

Trough comes complete with tamper resistant float valve & 50mm drain bung. Available in Beige only.





TANK AND DONUT TROUGH

Product Code	WCP4500TD	WCP9000TD
Volume	4,500L	9,000L
Drinking Vol.	330L	420L
Diameter	2.50m	3.05m
Height	2.00m	2.30m
Trough Width	0.325m	0.325m
Price	\$2,794	\$3,597

INCLUDES: 40mm (1½") tank outlet with isolation valve connected to trough float valve with flexible camlock coupling, 40mm trough drain bung & 40mm (1½") brass inlet with 1" (25mm) float valve. (Bottom fill inlet & larger float valves available at additional cost)



For easy connection & separation flexible coupling with camlock connection

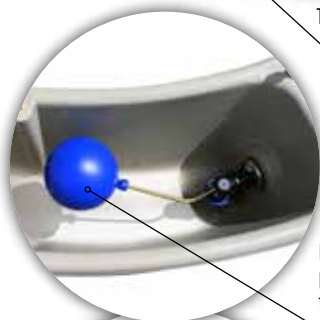

Trough surrounds tank for easier cleaning

High volume, low pressure **FLOAT VALVE** for steady water flow



DONUT TROUGH

Product Code	Volume	Diameter	Height	Trough Width	Price
WCP330DT	330L	2.50m	0.35m	0.325m	\$1,562
WCP420DT	420L	3.05m	0.35m	0.325m	\$1,892

INCLUDES: Removable float valve cover, 40mm drain bung and 40mm (1½") flexible camlock connection



STANDARD COLOURS

BEIGE

MIST GREEN

More colours available on request, see back of brochure



WATER STORAGE



ADVANCED MANUFACTURING TECHNOLOGY



MADE IN WESTERN AUSTRALIA



FREE DELIVERY
within 800kms of Perth



Suitable for Water & Liquid Fertiliser

LIQUID CARTAGE TANKS

WATER CARTAGE TANKS

When time efficiency matters, our new range of liquid cartage tanks can help make you more productive.

With a range of 600 -17,000 litres, like all of West Coast Poly's products our cartage tanks are designed to be lightweight yet strong and durable for our WA conditions. With large outlets for faster liquid flow, the new range of tanks will keep you going for longer.

CARTAGE TANKS - ORIGINAL RANGE

Product Code	Volume	Width	Length	Height	Water
WCP3500WC	3,500L	1.82m	2.37m	1.25m	\$3,498
WCP5400WC	5,400L	1.80m	3.22m	1.33m	\$4,532

CARTAGE TANKS

Product Code	Volume	Width	Length	Height	Water
WCP600WC	600L	1.13m	1.23m	0.71m	\$990
WCP800WC	800L	1.13m	1.23m	0.86m	\$1,232
WCP1000WC	1,000L	1.13m	1.23m	1.06m	\$1,441
WCP1500WC	1,500L	1.37m	1.73m	1.01m	\$1,980
WCP2000WC	2,000L	1.37m	1.73m	1.22m	\$2,552
WCP3000WC	3,000L	1.63m	2.33m	1.27m	\$3,619
WCP5000WC	5,000L	1.83m	2.58m	1.57m	\$5,060
WCP7000WC	7,000L	2.13m	3.33m	1.53m	\$6,864
WCP8500WC	8,500L	2.13m	3.33m	1.77m	\$8,019
WCP10500WC	10,500L	2.13m	3.83m	1.84m	\$9,702
WCP13000WC	13,000L	2.30m	4.43m	1.82m	\$12,507
WCP15000WC	15,000L	2.30m	4.43m	2.10m	\$14,234
WCP17000WC	17,000L	2.30m	4.43m	2.37m	\$15,730

STANDARD FITTINGS INCLUDE

WATER CARTAGE TANKS - Available in White or Natural (translucent):

600 - 2,000L: Poly outlet up to 50mm (2") with brass ball isolation valve, camlock & cap. Calibrated sight tube, solid stainless steel mounting pins, atmospheric vent and 350mm hinged polypropylene inspection hatch.

3,000 - 7,000L: Poly outlet up to 50mm (2") with brass ball isolation valve, camlock & cap. Inlet with camlock if required. Calibrated Sight tube with isolation valve, solid stainless steel mounting pins, 2 way atmospheric vent and 450mm polypropylene hinged inspection hatch.

8,500 - 17,000L: 1 x Brass outlet up to 80mm (3") with brass ball isolation valve, camlock and cap. Inlet with camlock if required. Calibrated Sight tube with isolation valve, solid stainless steel mounting pins, 2 way atmospheric vent and 450mm polypropylene hinged inspection hatch.



2 way Atmospheric vent



Stainless steel ball valve, camlock & cap



Calibrated site tube

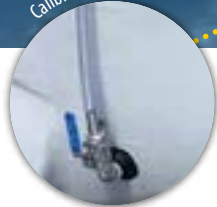

Hinged, lockable stainless steel lid



Mounting Pins



Stainless Steel Ladder
(Additional option)
\$825

LIQUID FERTILISER CARTAGE TANKS

Spend less time filling and more time spraying with our range of fertiliser cartage tanks.

Ranging from 600-17,000 litres, with the largest in the range able to fill up a 5000L sprayer 3.5 times, the equivalent to tripling your sprayer capacity. Constructed using a Linear Medium Density Polyethylene (LMDPE) and quality stainless steel fittings that provide outstanding chemical compatibility, corrosion resistance and faster liquid transfer, saving precious time during your busy periods.

CARTAGE TANKS - ORIGINAL RANGE

Product Code	Volume	Width	Length	Height	Liquid Fertiliser
WCP3500FC	3,500L	1.82m	2.37m	1.25m	\$3,960
WCP5400FC	5,400L	1.80m	3.22m	1.33m	\$5,775

CARTAGE TANKS

Product Code	Volume	Width	Length	Height	Liquid Fertiliser
WCP2000FC	2,000L	1.37m	1.73m	1.22m	\$2,970
WCP3000FC	3,000L	1.63m	2.33m	1.27m	\$4,213
WCP5000FC	5,000L	1.83m	2.58m	1.57m	\$6,050
WCP7000FC	7,000L	2.13m	3.33m	1.53m	\$8,371
WCP8500FC	8,500L	2.13m	3.33m	1.77m	\$9,295
WCP10500FC	10,500L	2.13m	3.83m	1.84m	\$11,440
WCP13000FC	13,000L	2.30m	4.43m	1.82m	\$14,245
WCP15000FC	15,000L	2.30m	4.43m	2.10m	\$16,027
WCP17000FC	17,000L	2.30m	4.43m	2.37m	\$17,358

*Sizes 600L - 1,500L available upon request.

STANDARD FITTINGS INCLUDE

LIQUID FERTILISER CARTAGE TANKS - Available in White or Natural (translucent):

2,000L: Poly outlet up to 50mm (2") with stainless steel ball isolation valve, camlock & cap. Calibrated sight tube, solid stainless steel mounting pins, atmospheric vent and 350mm polypropylene hinged inspection hatch.

3,000 - 7,000L: Poly outlet up to 50mm (2") with stainless steel ball isolation valve, camlock & dust cap. Inlet with camlock if required. Calibrated sight tube with isolation valve, solid stainless steel mounting pins, 2 way atmospheric vent and 400mm stainless steel hinged inspection hatch.

8,500 - 17,000L: Poly outlet up to 80mm (3") with stainless steel ball isolation valve, camlock & dust cap. Inlet with camlock if required. Calibration sight tube with isolation valve, solid stainless steel mounting pins, 2 way atmospheric vent, 400mm stainless steel hinged inspection hatch.



LIQUID FERTILISER CARTAGE



WATER CARTAGE



ADVANCED MANUFACTURING TECHNOLOGY



MADE IN WESTERN AUSTRALIA



FREE DELIVERY within 800kms of Perth



Suitable For Water & Liquid Fertiliser

LIQUID CARTAGE TANKS

EXTRA FITTINGS & ACCESSORIES

CARTAGE TANKS OPTIONAL EXTRAS:

- Stainless steel ladder for tank sizes 8,500L-17,000L at additional cost - **\$825**
- 600mm poly inspection hatch (7,000L-17,000L) - **\$198**
- 600mm stainless steel inspection hatch (7,000L-17,000L) - **\$1,650**
- Skid Frames - **SEE PAGE 14**
- 4" outlets or larger flanged style - **available on request**

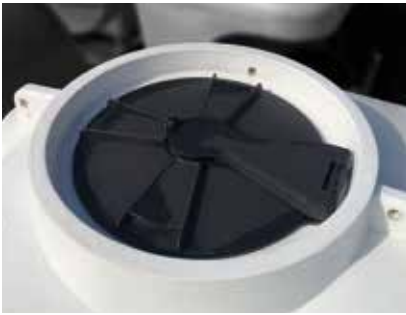

BAFFLE BALLS - 355mm CLIP LOCK

Designed for the safer transportation of liquid, our baffle balls reduce liquid surge within the tank when cornering and braking. This improves the safety and stability of your vehicle.

Product Code	Baffle Balls	Unit Price
WCPBAFF	Supply Only - <i>unassembled</i> (1ball per 40L)	\$8.80
WCPBAFFTP	Assembled & Installed in Tank (1ball per 40L)	\$12.10

*Recommend filling 100% of the tank.



WHY OUR BAFFLE BALLS?

- Vehicle stability and hazard mitigation
- Reduction in maintenance costs
- Food grade polypropylene
- Virtual Volume (1% actual volume)
- 6 securing clips means these don't come apart like many other baffle balls
- Our baffle ball occupies less than 1% of total tank volume



Cartage Tanks SKID FRAMES

SKID FRAMES - CARTAGE TANKS

Our skid frames are designed & made in house at our modern Canning Vale facility & are commercial heavy duty grade. The West Coast Poly HD Skids are HDG (Hot Dipped Galvanised) for high durability. With usability in mind we designed our skid frames with multi sided fork tine lifting points giving you maximum versatility and mobility for your cartage tanks.

We can customise our skid frames to suit whatever needs you require, simply contact our friendly sales team.



RANGE AND DIMENSIONS - Hot dipped Galvanised

Product Code	Volume	Width	Length	Price
WCP600SF	600L	1.13m	1.23m	\$2,607
WCP800SF	800L	1.13m	1.23m	\$2,607
WCP1000SF	1,000L	1.13m	1.23m	\$2,607
WCP1500SF	1,500L	1.37m	1.73m	\$4,378
WCP2000SF	2,000L	1.37m	1.73m	\$4,378
WCP3000SF	3,000L	1.63m	2.33m	\$6,820
WCP5000SF	5,000L	1.83m	2.58m	\$7,282

Product Code	Volume	Width	Length	Price
WCP7000SF	7,000L	2.13m	3.33m	\$9,482
WCP8000SF	8,500L	2.13m	3.33m	\$9,482
WCP10500SF	10,500L	2.13m	3.83m	\$10,032
WCP13000SF	13,000L	2.43m	4.53m	\$10,978
WCP15000SF	15,000L	2.43m	4.53m	\$10,978
WCP17000SF	17,000L	2.43m	4.53m	\$10,978

FOR MORE INFORMATION, CALL OUR SALES TEAM ON (08) 9456 5888

Secure Storage LIQUID FERTILISER

Secure Liquid Fertiliser Storage, so you can focus on the seasons ahead.

Expertly designed these tanks are fully engineer FEA certified, single piece roto-moulded construction, with unmatched strength and durability. With a range of clever features and backed by a 15 year guarantee, West Coast Poly has your agricultural liquid fertiliser storage covered, so you can get on with farming.

Product Code	Volume	Volume (Tonne)	Diameter	Apex Height	Price
WCP25000LF	25,000L	33	3.78m	2.60m	\$7,084
WCP50000LF	50,000L	66	4.60m	3.45m	\$12,991



MAX Specific Gravity = 1.32



STANDARD FITTINGS INCLUDE

- 3" (80mm) HDPE poly infill line with stainless steel non return valve, camlock and dust cap and 13mm drain valve
- 2" (50mm) or 3" (80mm) suction outlet - Stainless steel isolation ball valve with camlock connection & dust cap
- Screwed inspection hatch
- Liquidator - tank mounted mechanical level gauge
- 4 tie down points
- FEA engineering certified

Fast Batch Turnover FERTILISER MIXING TANKS

Giving you on-site mixing capabilities for agricultural fertiliser mixing, while also providing the flexibility to tailor specific formulas that suit your application needs.

The West Coast Poly mechanical/electric mixer comprises of a vertical prop shaft with a roof mounted electric motor & gear box, driving a stainless steel prop shaft, designed specifically for your process application.

With our vast tank manufacturing experience, our mechanical mixer engineering team, have a mixer tank solution for your needs. Whether it be low level, high velocity or process stirring, fully draining floors, a tank can be made to your requirements.



Product Code	Volume	Height	Diameter	Mixing Volume (Suggested Batch Vol.)	Price
WCP5000MX	5,000L	1.30m	2.35m	4,000L	\$13,024
WCP9000MX	9,000L	1.50m	2.85m	8,000L	\$14,069
WCP14000MX	14,000L	2.20m	2.85m	12,000L	\$14,619
WCP25000MX	25,000L*	2.60m	3.78m	22,000L	\$20,196
WCP38000MX	38,000L*	3.15m	4.30m	35,000L	\$29,073
WCP50000MX	50,000L*	3.45m	4.60m	47,000L	\$31,306

Pricing represents 240v units -415v available on request.

STANDARD FITTINGS INCLUDE

- 240v single batch mixers
- 5,000L to 14,000L: 50mm (2") poly outlet + ball valve
- 25,000L to 50,000L: 80mm (3") poly outlet + stainless steel ball valve.
- Hinged PE loading hatch

ADDITIONAL OPTIONS

- Low level/variable batch mixers
- 415v mixers
- Internal baffles
- Flanged fittings
- Fully draining floor
- Level indicator
- **OTHER TANK SIZES ON REQUEST**

APPLICATIONS

- Chemical applications
- Fertiligation
- Individual recipes combinations
- Broadacre/Viticulture/Horticulture

BENEFITS

- High agitation rate for rapid batch turnaround
- Aggressive floor scouring to prevent sediment
- Versatility to produce specific fertiliser/chemical recipes

*Additional oversize delivery charge P.O.A. 38,000L and 50,000L require mixer to be installed onsite, extra cost involved depending on delivery destination.

Storage and Cartage DIESEL TANKS

DIESEL STORAGE TANKS

Keep your machinery going for longer, our diesel tanks are a reliable back-up during those busy seasons.

Designed and manufactured to be strong and durable for our WA conditions. Ideal for both secure diesel storage and fast convenient diesel delivery, keep your machinery going for longer with our range of diesel tanks.

DIESEL STORAGE TANKS + ITALIAN MADE PIUSI PUMP KIT

5,000L	WITH PUMP	NO PUMP
Product Code	WCP5000DSP	WCP5000DS
Diameter	1.93m	1.93m
Apex Height	2.07m	2.07m
Price	\$9,328	\$4,752

10,000L	WITH PUMP	NO PUMP
Product Code	WCP10000DSP	WCP10000DS
Diameter	2.35m	2.35m
Apex Height	2.64m	2.64m
Price	\$10,329	\$5,951

STANDARD FITTINGS INCLUDE

TANKS INCLUDE:

- 50mm (2") Fill line
 - 40mm Lockable drain valve
 - Fully sealed roof to prevent water ingress
 - Volume level sight tube with isolation valve
 - 80mm (3") Overflow port with ingress protection and vermin proof screen
 - Earth/Ground cable
- OTHER SIZES AVAILABLE ON REQUEST**

WITH PUMP:

- 12v or 240v Italian made PIUSI Diesel pump kit
- Flow meter sealed within steel cabinet
- Earth/Ground cable
- Flow rates of 80L/min for the 12v and 90L/min for the 240v
- Delivery hose with auto shut off nozzle: 12v = 4m hose & 240v = 7.5m hose



Optional 240v Cube 90 Diesel Pump on Pedestal Stand

STANDARD FOR THE STORAGE OF DIESEL FUEL (AS1940:2017)

West Coast Poly diesel tanks are designed in accordance with AS1940:2017 storage and handling of combustible liquids.

Tank installation including bund requirements are the responsibility of the user and should be as per required in accordance with AS1940:2017.



Stainless Steel Mounting Pins

DIESEL CARTAGE TANKS

Keep the engine hours in the paddock and not on the drive to fill up.

Ranging from 600 - 10,500 litres, made using West Coast Poly's superior manufacturing method resulting in a tank that is light weight yet strong and durable ensuring your diesel is properly cared for.

DIESEL CARTAGE TANKS

Product Code	Volume	Width	Length	Height	Price
WCP600DC	600L	1.13m	1.23m	0.71m	\$1,155
WCP800DC	800L	1.13m	1.23m	0.86m	\$1,507
WCP1000DC	1,000L	1.13m	1.23m	1.06m	\$1,683
WCP1500DC	1,500L	1.37m	1.73m	1.01m	\$2,222
WCP2000DC	2,000L	1.37m	1.73m	1.22m	\$2,926
WCP3000DC	3,000L	1.63m	2.33m	1.27m	\$4,136
WCP5000DC	5,000L	1.83m	2.58m	1.57m	\$5,951
WCP7000DC	7,000L	2.13m	3.33m	1.53m	\$7,788
WCP8500DC	8,500L	2.13m	3.33m	1.77m	\$8,998
WCP10500DC	10,500L	2.13m	3.83m	1.84m	\$11,000

STANDARD FITTINGS INCLUDE

- Lockable 50mm (2") fill cap • Lockable 1½ ball valve • Level indicator + lockable isolation valve
- Atmospheric vent • Stainless steel mounting pins

PUMP KITS AND SKID FRAMES AVAILABLE



DIESEL STORAGE SOLUTIONS



ADVANCED MANUFACTURING TECHNOLOGY



MADE IN WESTERN AUSTRALIA



FREE DELIVERY
within 800kms of Perth



Secure Storage ADBLUE STORAGE TANK

West Coast Poly's AdBlue tanks are expertly designed to give you total peace of mind, knowing that your AdBlue is stored securely.

Their heavy duty and single piece roto-moulded construction gives these tanks unmatched strength and durability. While also coming with a Piusi pump kit as standard, to give you easy access to your AdBlue onsite.

For a complete AdBlue storage solution that meets the needs of your modern high performance diesel engines, it has to be West Coast Poly.

ADBLUE STORAGE TANKS + ITALIAN MADE PIUSI PUMP KIT

Product Code	Volume	Diameter	Apex Heigh	Price
WCP10000AS	10,000L	2.35m	2.64m	\$11,627
WCP5000AS	5,000L	1.93m	2.07m	\$9,559

**OTHER SIZES
AVAILABLE ON
REQUEST**



STANDARD FITTINGS INCLUDE

- 12v or 240v PIUSI AdBlue Pump Kit with flow meter sealed within steel cabinet
- Flow rate of 35L/min
- 5m delivery hose plus auto shut off nozzle
- 2" fill line
- 40mm lockable drain valve
- Volume level site tube with isolation valve
- 3" overflow port with ingress protection and vermin proof screen
- Fully sealed roof to prevent water ingress



MAXIMUM STRENGTH MAXIMUM DURABILITY

COMMERCIAL & INDUSTRIAL TANKS

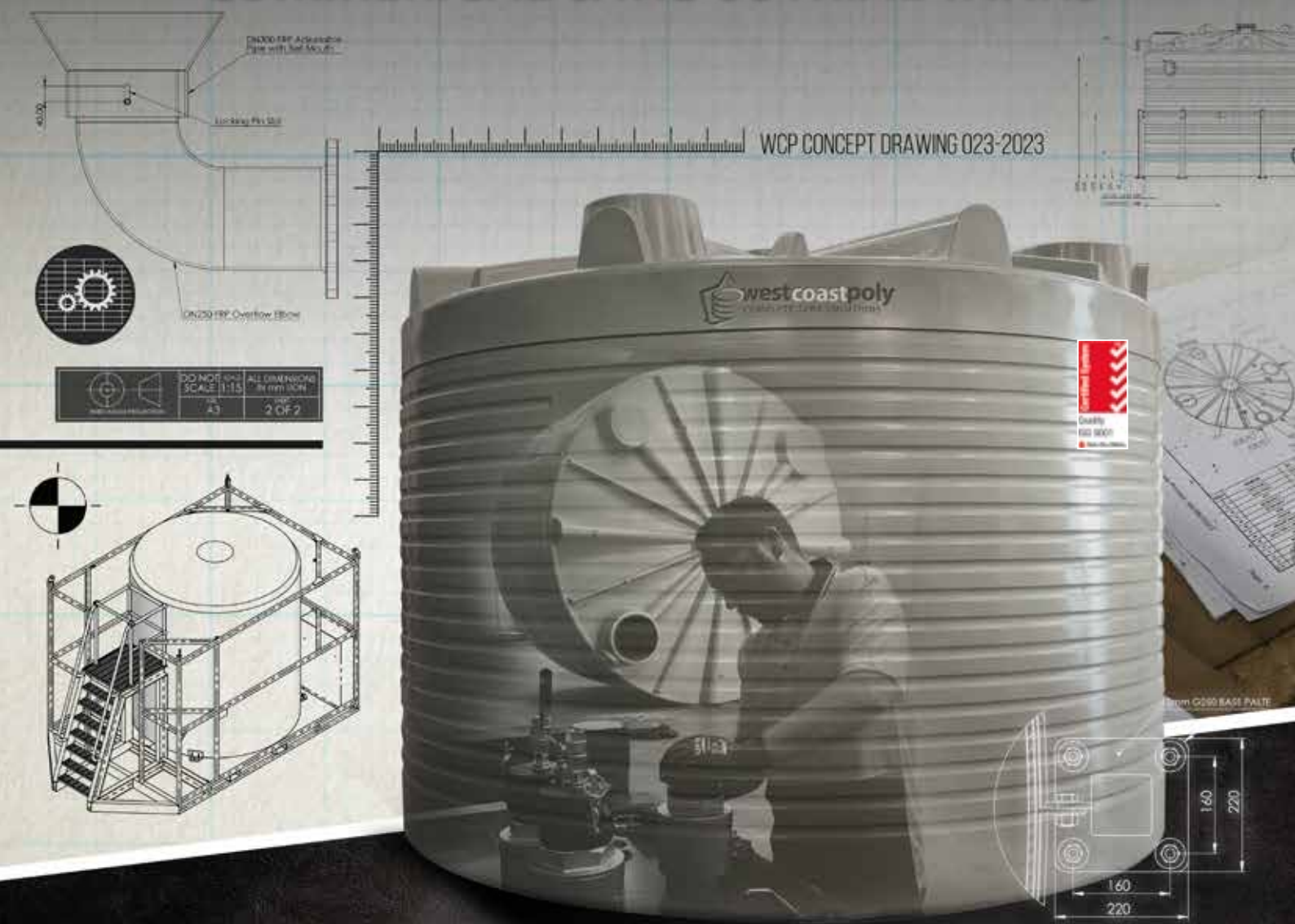

West Coast Poly's commitment to excellence in manufacturing produces the highest quality polyethylene tanks, suitable for a wide range of industrial and mining applications.

PORTABLE | WATER | CYCLONIC | CARTAGE | DIESEL | MIXING | INSULATED | CUSTOM TANKS

Water Storage Tanks RESIDENTIAL RANGE

We offer a range of domestic rainwater tanks to suit the suburban environment.



Our tanks are fully certified and manufactured for the household blocks where space is limited. Slimline tanks that fit neatly under the eaves and traditional round tanks make up the residential.

The rainwater tanks are available in a range of sizes, styles and colours. You are sure to find the perfect tank for your requirements to complement the surrounding environment of your home.

RESIDENTIAL TANKS BENEFITS:

- Space saving designs
- Can be placed directly onto pavers
- Reinforced band allows tap placement for easy access
- Easy to relocate
- Manufactured locally in Western Australia with a 10 year guarantee
- Variety of colours, UV resistant

WHY A WATER TANK FOR YOUR HOME?

A simple water tank can help you adapt to Australia's unique changing seasons, from droughts to flooding rains, a water tank can help your household make the most of seasonal situations.

During rains, the excessive water run off that cascades into the garden eroding soil, will now instead be collected into your tank, stored, then used as a saviour in the dry months. Utilise the collected water to wash your clothes, flush your toilet or water thirsty gardens, and watch them thrive, even in the dry summer months.

These utilisations leave you less reliant on the water mains and in turn can reduce the cost of your water bill, on top of making your property more environmentally sustainable.



INSTALLATION



Scan me



Scan our QR code for installation of residential tank guidelines

“ Utilise collected rainwater for your washing machine, toilets or water thirsty gardens”

COLOURS AVAILABLE: Indication only. Colours may vary with the printing process. More colours available, see back of brochure.

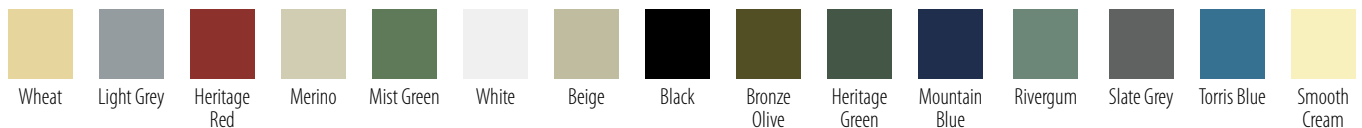



ROUND TANKS

Name/Size	Product Code	Diameter	Wall Height	Height/Inlet	Price
320L Mini	WCP320R	0.58m	1.19m	1.26m	\$462
550L Tall	WCP550R	0.62m	1.95m	2.0m	\$539
720L Courtyard	WCP720R	0.80m	1.50m	1.60m	\$583
1,200L Midi	WCP1200R	1.05m	1.44m	1.54m	\$715
2,500L Suburban	WCP2500R	1.42m	1.62m	1.86m	\$979
3,700L Backyard	WCP3700R	1.65m	1.75m	2.0m	\$1,188

SLIMLINE TANKS

Name/Size	Product Code	Height/Inlet	Width	Length	Price
Slimline 1,500L	WCP1500SL	1.86m	0.80m	1.40m	\$968
Space Saver 2,500L	WCP2500SL	2.08m	0.715m	2.35m	\$1,496
Terrace 3,000L	WCP3000SL	1.99m	0.80m	2.52m	\$1,628

YOUR TANK COMES INSTALLED WITH STANDARD FITTINGS:

- 19mm outlet tap
- 50mm overflow: sizes 320L - 1,500L
- 19mm drain bung
- 90mm overflow: sizes 2,500L - 3,700L
- Easy maintenance leaf strainer
- Screw top lid
- Available in a range of colours matched to the Colorbond® range



PLEASE NOTE: A delivery charge of \$110 applies to all Residential Tanks (320L - 3,700L), delivered direct to customers within 800kms of the Canning Vale factory.



Slimline tanks: 1,500L, 2,500L, 3,000L



WATER STORAGE



ADVANCED MANUFACTURING TECHNOLOGY



MADE IN WESTERN AUSTRALIA



RAIN WATER HARVESTING

All In One Automatic Rainwater Harvesting Systems.

An all-in-one system where technology does the work for you when it comes to collecting and utilising your rainwater for inhouse reuse.

If your rainwater tank is running low, the roof mounted controller automatically switches the water flowing to the house from the tank to water directly from the water mains. Switching back to rainwater automatically once your tank's water is replenished. It will always use rainwater first and you will always have an uninterrupted waterflow to your home.

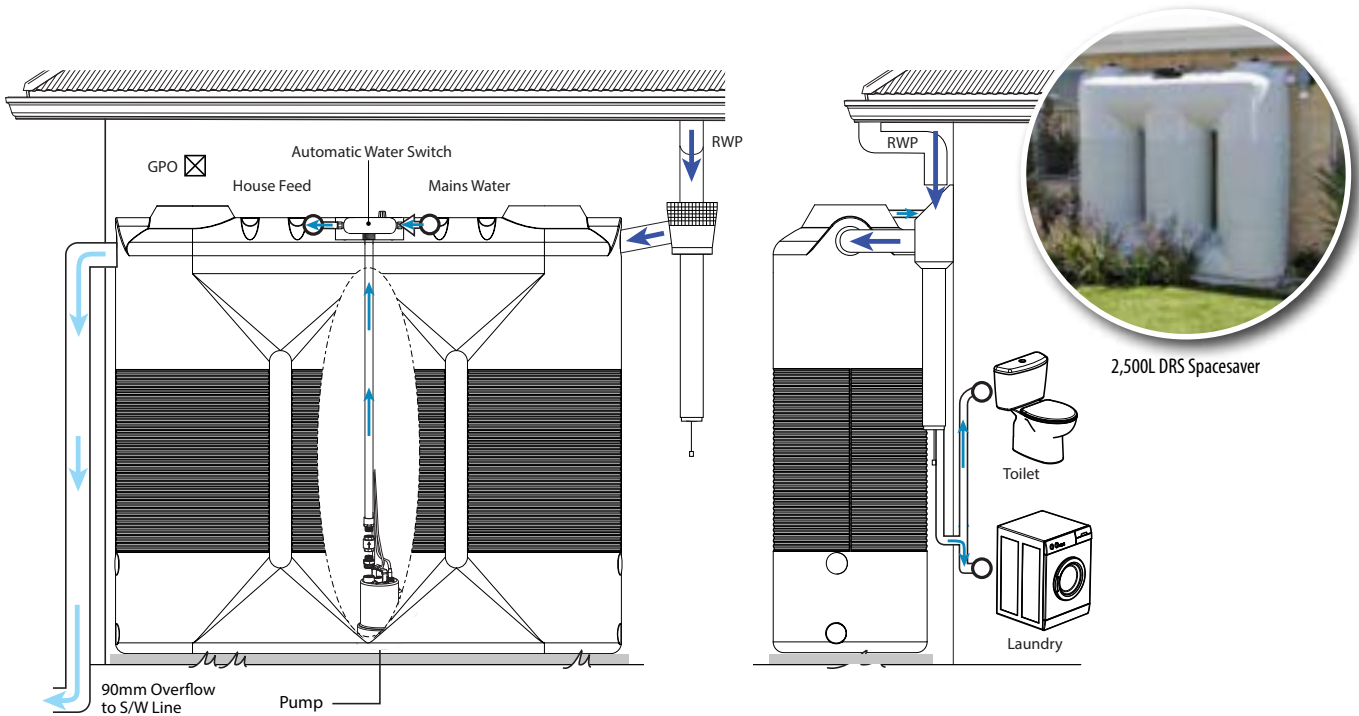

AUTOMATIC RAINWATER HARVESTING SYSTEM INCLUDE:



Roof Mounted Auto Water Switch Controller, Mains Water Isolation Valve + SS Connection Hoses



Divertron 1200 Submersible Pump



Standard 90mm Overflow Port



250mm Leaf Strainer Inlet



19mm Outlet Tap



250mm Screwed Inspection Hatch

RAINWATER HARVESTING SYSTEM + ROUND TANK

Volume	Product Code	Diameter	Wall Height	Height/Inlet	Price
2,500 - DRS Round	WCP2500RDRS	1.42m	1.62m	1.86m	\$2,464

RAINWATER HARVESTING SYSTEM + SLIMLINE TANK

Volume	Product Code	Height/Inlet	Width	Length	Price
1,500L - DRS Slimline	WCP1500SDRS	1.86m	0.80m	1.40m	\$2,431
2,500L - DRS Spacesaver	WCP2500SDRS	2.08m	0.715m	2.35m	\$2,948
3,000L - DRS Terrace	WCP3000SDRS	1.99m	0.80m	2.52m	\$3,190

Other tank sizes are available on request. Installation is an additional cost. A delivery charge of \$110 applies to all Residential Tanks (320L - 3,700L) within 800kms of the Canning Vale factory.

EXTRA FITTINGS & ACCESSORIES

Build the ideal water tank solution package for your home with our range of quality accessories.

Make sure you make the most of your new water tank and deliver a high volume of quality water into your home.

We have categorised our range of residential tank accessories in 5 easy steps to help you design the perfect water tank solution for your home.

1. COLLECT AND PROTECT YOUR RAIN WATER

Keep debris out of your rain harvesting system so it stays clean



LEAF EATER ADVANCED - \$66

Easily mounted, it prevents leaves entering the catchment pipes with it's fine mesh screen.



TOTAL RAIN - \$165

The ultimate all-in-one rainwater cleaning device, filters leaves and diverts the first flush.

2. DIVERT YOUR RAINWATER

Divert contaminated roof run off keeping your tank clean



FIRST FLUSH WATER DIVERTER - \$46.20

Gives your tank the best water by diverting the first flush of rain water from your roof.



FIRST FLUSH CARROT WATER DIVERTER - \$99

Its unique compact design takes up minimal space & diverts the first flush without the chamber.

3. WATER MOVEMENT

Make sure your water flows to where you need it too



ONGA JMP100 PUMP - \$638

An economical household pressure system with high performance & reliability.



DAVEY HP65-06T WITH TORRIUM2 - \$1,419

Offers perfect water pressure with a small water pump that can fit into a tight spot.

4. FINAL STAGE FILTRATION

Ensure your water is ready to use through proper filtering



DAVEY TWIN FILTER HOUSINGS AS10J - \$462

Davey twin filter housing kits are assembled side by side on a stylish bracket for ease of installation.



DAVEY UV WATER DISINFECTION KUV57A - \$2,200

Delivers safe, clean water - using the power of ultra violet light for reliable, effective, chemical-free disinfection.

OTHER FILTRATION SOLUTIONS AVAILABE UPON REQUEST

5. MONITOR YOUR WATER LEVEL

Solutions that allows you to easily check the water level in your tank at a glance



LEVETATOR - LEVEL INDICATOR - \$132

Accurately shows the level of water on the water tank wall. Great for tanks on stands & residential tanks.

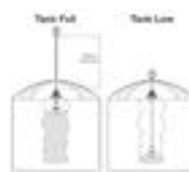

HANSEN LEVEL ALERT - \$286

A maintenance free simple fluid level indicator that can be mounted on tank. Features easy adjust nut & security lock, HiViz Low wind resistant float & stainless steel fastenings.

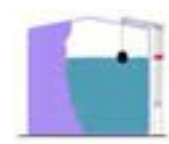

LIQUIDATOR V2 - \$276

The Liquidator uses a vertical guide tube. The indicator slides up and down on the outside of the tube while the counterweight is contained in it.

PRODUCT PRICE LIST

Effective January 1st 2024

AGRICULTURAL RANGE

WATER STORAGE TANKS

Product Code	Volume	Price
WCP4500R	4,500L	\$1,309
WCP5300R	5,300L	\$1,518
WCP9000R	9,000L	\$2,134
WCP10000R	10,000L	\$2,541
WCP14000R	14,000L	\$2,739
WCP23000R	23,000L	\$3,707
WCP25000R	25,000L	\$3,872
WCP27500R	27,500L	\$4,411
WCP38000R	38,000L	\$6,996
WCP50000R	50,000L	\$9,372

WATER STORAGE TANKS COMBO RANGE

Product Code	Combos	Price
WCP23000RCOM	2 x 23,000L (46,000L)	\$7,238
WCP25000RCOM	2 x 25,000L (50,000L)	\$7,590
WCP27500RCOM	2 x 27,500L (55,000L)	\$8,536
WCP38000RCOM	2 x 38,000L (76,000L)	\$13,607
WCP50000RCOM	2 x 50,000L (100,000L)	\$18,348

FLEXIBLE COUPLINGS

Product Code	Size	Price
WCPFLX40X500	40mm (1 1/2")	\$110
WCPFLX50X500	50mm (2")	\$132
WCPFLX80X500	80mm (3")	\$242

BALL VALVES

Product Code	Size	Price
WCP25BV	25mm (1")	\$22
WCP32BV	32mm (1 1/4")	\$33
WCP40BV	40mm (1 1/2")	\$44
WCP50BV	50mm (2")	\$66
WCP80BV	80mm (3")	\$198

BRASS OUTLETS

Product Code	Size	Price
WCP25BO	25mm (1")	\$22
WCP32BO	32mm (1 1/4")	\$33
WCP40BO	40mm (1 1/2")	\$44
WCP50BO	50mm (2")	\$66
WCP80BO	80mm (3")	\$176

LEVEL GAUGES

Product Code	Gauges	Price
WCPLI	Levetator - Level Indicator	\$132
WCPLV2	Liquidator v2	\$275
WCPHLA	Hansen Level Alert	\$286

Level gauge, supplied only

FIRE GUARD - COMPACT FF UNITS

Product Code	Volume	Price
WCP600FF	600L	\$5,797
WCP800FF	800L	\$5,995
WCP1000FF	1,000L	\$6,182

FIRE GUARD SKID MOUNTED FIRE RESPONDERS

Product Code	Volume	Price
WCP600FR	600L	\$5,797
WCP800FR	800L	\$5,995
WCP1000FR	1,000L	\$6,182
WCP1500FR	1,500L	\$7,590
WCP2000FR	2,000L	\$7,920
WCP3000FR	3,000L	\$8,965

FIREGUARD OPTIONAL EXTRAS

Product Code	Gauges	Price
WCPR	Individual Hose Reel	\$990
WCPHR	Individual Hose Reel + 1" Fire Hose & Nozzle	\$1,276

RECTANGULAR SUPA TROUGH

Product Code	Volume	Price
WCP550ST	550L	\$1,485
WCP800ST	800L	\$1,705

RECTANGULAR LONG TROUGH

Product Code	Volume	Price
WCP170LT	170L	\$913
WCP300LT	300L	\$1078

HEAVY DUTY ROUND TROUGH

Product Code	Volume	Price
WCP1200RT	1,200L	\$814

TANK AND DONUT TROUGH

Product Code	Vol	Drinking Vol	Price
WCP4500TD	4,500L	330L	\$2,794
WCP9000TD	9,000L	420L	\$3,597

DONUT TROUGH

Product Code	Volume	Price
WCP330DT	330L	\$1,562
WCP420DT	420L	\$1,892

CARTAGE TANKS

Product Code	Volume	Water
WCP600WC	600L	\$990
WCP800WC	800L	\$1,232
WCP1000WC	1,000L	\$1,441
WCP1500WC	1,500L	\$1,980
WCP2000WC	2,000L	\$2,552
WCP3000WC	3,000L	\$3,619
WCP5000WC	5,000L	\$5,060
WCP7000WC	7,000L	\$6,864
WCP8500WC	8,500L	\$8,019
WCP10500WC	10,500L	\$9,702
WCP13000WC	13,000L	\$12,507
WCP15000WC	15,000L	\$14,234
WCP17000WC	17,000L	\$15,730

CARTAGE TANKS - ORIGINAL RANGE

Product Code	Volume	Water
WCP3500WC	3,500L	\$3,498
WCP5400WC	5,400L	\$4,532

CARTAGE TANKS - ORIGINAL RANGE

Product Code	Volume	Liquid Fertiliser
WCP3500FC	3,500L	\$3,960
WCP5400FC	5,400L	\$5,775

CARTAGE TANKS

Product Code	Volume	Liquid Fertiliser
WCP2000FC	2,000L	\$2,970
WCP3000FC	3,000L	\$4,213
WCP5000FC	5,000L	\$6,050
WCP7000FC	7,000L	\$8,371
WCP8500FC	8,500L	\$9,295
WCP10500FC	10,500L	\$11,440
WCP13000FC	13,000L	\$14,245
WCP15000FC	15,000L	\$16,027
WCP17000FC	17,000L	\$17,358

CARTAGE TANKS OPTIONAL EXTRAS

Product Code	Gauges	Price
WCPSSL	SS ladder (8,500L-17,000L)	\$825
WCP600PIH	600mm Poly Inspection hatch (7,000L-17,000L)	\$198
WCP600SIH	600mm SS Inspection hatch (7,000L-17,000L)	\$1,650

BAFFLE BALLS

Product Code	Baffle Balls	Unit Price
WCPBAFF	Supply Only - unassembled (1ball per 40L)	\$8.80
WCPBAFFTP	Assembled & Installed (1ball per 40L)	\$12.10

LIQUID FERTILISER MIXING TANKS

Product Code	Volume	Price
WCP5000MX	5,000L	\$13,024
WCP9000MX	9,000L	\$14,069
WCP14000MX	14,000L	\$14,619
WCP25000MX	25,000L*	\$20,196
WCP38000MX	38,000L*	\$29,073
WCP50000MX	50,000L*	\$31,306

*Additional oversize delivery charge P.O.A.

LIQUID FERTILISER STORAGE TANKS

Product Code	Volume	Price
WCP25000LF	25,000L (33T)	\$7,084
WCP50000LF	50,000L (66T)	\$12,991

DIESEL STORAGE TANKS + ITALIAN MADE PIUSI PUMP KIT

Product Code	Volume	WITH PUMP
WCP5000DSP	5,000L	\$9,328
WCP10000DSP	10,000L	\$10,329

DIESEL STORAGE TANKS

Product Code	Volume	NO PUMP
WCP5000DS	5,000L	\$4,752
WCP10000DS	10,000L	\$5,951

ADBLUE STORAGE TANK + ITALIAN MADE PIUSI PUMP KIT

Product Code	Volume	WITH PUMP
WCP10000AS	10,000L	\$11,627
WCP5000AS	5,000L	\$9,559

DIESEL CARTAGE TANKS

Product Code	Volume	Price
WCP600DC	600L	\$1,155
WCP800DC	800L	\$1,507
WCP1000DC	1,000L	\$1,683
WCP1500DC	1,500L	\$2,222
WCP2000DC	2,000L	\$2,926
WCP3000DC	3,000L	\$4,136
WCP5000DC	5,000L	\$5,951
WCP7000DC	7,000L	\$7,788
WCP8500DC	8,500L	\$8,998
WCP10500DC	10,500L	\$11,000

SKID FRAMES - Hot Dipped Galvanised

Product Code	Volume	Price
WCP600SF	600L	\$2,607
WCP800SF	800L	\$2,607
WCP1000SF	1,000L	\$2,607
WCP1500SF	1,500L	\$4,378
WCP2000SF	2,000L	\$4,378
WCP3000SF	3,000L	\$6,820
WCP5000SF	5,000L	\$7,282
WCP7000SF	7,000L	\$9,482
WCP8000SF	8,500L	\$9,482
WCP10500SF	10,500L	\$10,032
WCP13000SF	13,000L	\$10,978
WCP15000SF	15,000L	\$10,978
WCP17000SF	17,000L	\$10,978

RESIDENTIAL RANGE

ROUND TANKS

Product Code	Name/Size	Price
WCP320R	320L Mini	\$462
WCP550R	550L Tall	\$539
WCP720R	720L Courtyard	\$583
WCP1200R	1,200L Midi	\$715
WCP2500R	2,500L Suburban	\$979
WCP3700R	3,700L Backyard	\$1,188

SLIMLINE TANKS

Product Code	Name/Size	Price
WCP1500SL	Slimline 1,500L	\$968
WCP2500SL	Space Saver 2,500L	\$1,496
WCP3000SL	Terrace 3,000L	\$1,628

RAIN WATER HARVESTING SYSTEM AND TANK

Product Code	Name/Size	Price
WCP2500RDRS	2,500 - DRS Round	\$2,464
WCP1500SDRS	1,500L - DRS Slimline	\$2,431
WCP2500SDRS	2,500L - DRS Spacesaver	\$2,948
WCP3000SDRS	3,000L - DRS Terrace	\$3,190

TANK ACCESSORIES (RESIDENTIAL)

Product Code	Product	Price
WCPLEA	Leaf Eater Advanced	\$66
WCPTR	Total Rain	\$165
WCPFFWD	First Flush Water Diverter	\$46.20
WCPFFCWD	First Flush Carrot Water Diverter	\$99
WCPJMMMP	Onga JMP 100 Pump	\$638
WCPDTP	Davey HP65-06T + Torrium2	\$1,419
WCPDTFHP	Davey Twin Filter Housing AS10J	\$462
WCPDUVWD	Davey UV Water Disinfection KUV57A	\$2,200
WCPLI	Levetator	\$132
WCPHLA	Hansen Level Alert	\$286
WCPLV2	Liquidator V2	\$275



Colour Range

Colours in brackets (colour matching guide): Colourbond® steel Premium range Ultra steel & Stainless steel

NOTE: Colours shown are an indication only, colour may vary. If colour required not shown, contact us for more options.



Owned and Manufactured in WA.

Copyright of material displayed in this brochure remains the property of West Coast Poly Pty Ltd.



Delivery:

Rural Tanks - Free Delivery (within 800kms from Perth*)

Standard fittings are installed on-site to ensure placement is to your requirements. Delivery is efficient with a fast turnaround from order to delivery.

All Residential Tanks (320L - 3,700L) - DELIVERY FEE \$110

In the Perth metro area urban tanks are delivered directly to residences by courier transport. Regional areas within 800km of Perth are delivered by West Coast Poly's fleet of trucks.

Available from: